

# Stechen, schmale Sicherungsringnuten, reduzierte Stechtiefe

Sicherungsringnuten, vgl. DIN 471/472 sowie DIN 983/984.  
Reduzierte Stechtiefe.

## Grooving, Circlip Ring Grooves, Slim Widths, With Reduced Cutting depth

Circlip ring grooves comp. to DIN 471/472 and DIN 983/984.  
Reduced cutting depth.

Schnittwerte (Start) // Cutting parameters (start)

f	Vc
0,04 mm/U	Seite/Page 429

Passende Klemmhalter auf Seite // Suitable toolholders on page  
**361, 362, 363, 364, 365, 367, 368**

**SP**
**HM**
Legende  
Legend
**389**

 Scan QR-Code
 Oder besuchen Sie // Or Visit [www.simtek.info/cp/499](http://www.simtek.info/cp/499)

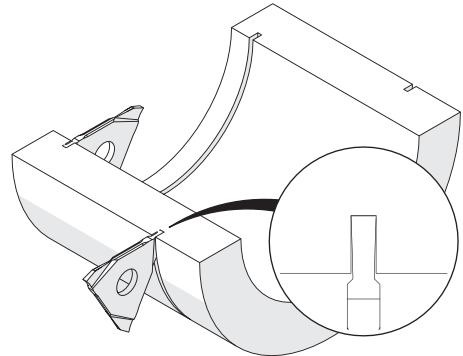
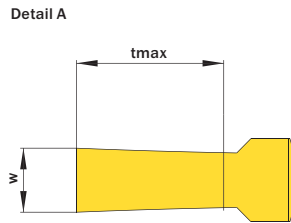
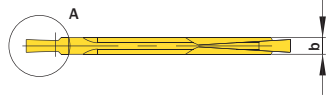
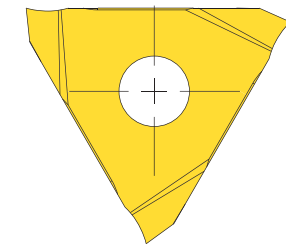

Abbildung zeigt / Drawing shows: E12.1094.00 Z

b ±0,02 mm	Nennbreite Nominal width of mm	Artikelnummer Part number	Webcode www.simtek.com/webcode	Unsere erste Wahl Our first choice	tmax mm	w <sup>-0,05</sup> mm	Connectcode www.simtek.com/ccode
1,3	0,34	<b>E12.1034.00 Z</b>	AHE9	X808 X408	0,6	0,4	E12.A1 E12.A2
1,3	0,44	<b>E12.1044.00 Z</b>	AJAV	X808 X408	0,7	0,5	E12.A1 E12.A2
1,3	0,5	<b>E12.1050.00 Z</b>	ANE0	X808 X408	0,9	0,57	E12.A1 E12.A2
1,3	0,54	<b>E12.1054.00 Z</b>	AHZF	X808 X408	0,8	0,6	E12.A1 E12.A2
1,3	0,6	<b>E12.1060.00 Z</b>	APXN	X808 X408	1,1	0,67	E12.A1 E12.A2
1,3	0,64	<b>E12.1064.00 Z</b>	AC2C	X808 X408	1,0	0,7	E12.A1 E12.A2
1,3	0,7	<b>E12.1070.00 Z</b>	AD4M	X808 X408	1,7	0,77	E12.A1 E12.A2
1,3	0,74	<b>E12.1074.00 Z</b>	ANH3	X808 X408	1,7	0,8	E12.A1 E12.A2
1,3	0,8	<b>E12.1080.00 Z</b>	ADDH	X808 X408	2,3	0,87	E12.A1 E12.A2
1,3	0,85	<b>E12.1085.00 Z</b>	AAUW	X808 X408	2,3	0,91	E12.A1 E12.A2
1,3	0,9	<b>E12.1090.00 Z</b>	ADHX	X808 X408	2,3	0,97	E12.A1 E12.A2
1,3	0,94	<b>E12.1094.00 Z</b>	AMUD	X808 X408	2,3	1,0	E12.A1 E12.A2
1,3	1,0	<b>E12.1100.00 Z</b>	AB93	X808 X408	2,3	1,07	E12.A1 E12.A2
1,3	1,05	<b>E12.1105.00 Z</b>	AH3J	X808 X408	2,3	1,12	E12.A1 E12.A2
1,3	1,1	<b>E12.1115.00 Z</b>	AEHY	X808 X408	2,5	1,22	E12.A1 E12.A2

Bestellbeispiel // Order example: **E12.1094.00 Z X808** (X808 = Schneidstoff // Grade)