

Nutenstechen

Für allgemeines Nutenstechen und für Sicherungsringnuten.
Geeignet ab Bohrungsdurchmesser 20,0 mm.

Grooving

For general grooving as well as for circlip ring grooving.
For use in bores as of minimum bore diameter 20,0 mm.

Schnittwerte (Start) // Cutting parameters (start)

f	Vc
0,02 mm/U	Seite/Page 429

Passende Klemmhalter auf Seite // Suitable toolholders on page
160, 164

Vergleichbare Werkzeuge auf Seite // Similar tools on page
175

SP

HM

R

Legende
Legend **213**

Scan
QR-Code
 Oder besuchen Sie // Or Visit
www.simtek.info/cp/857

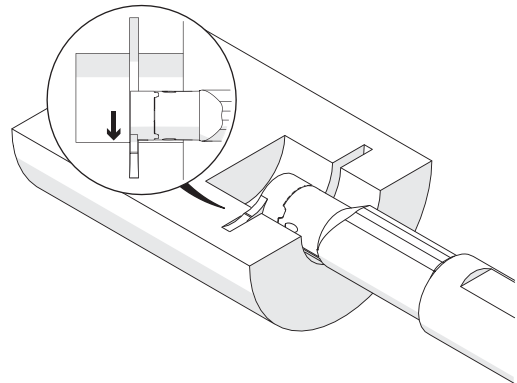
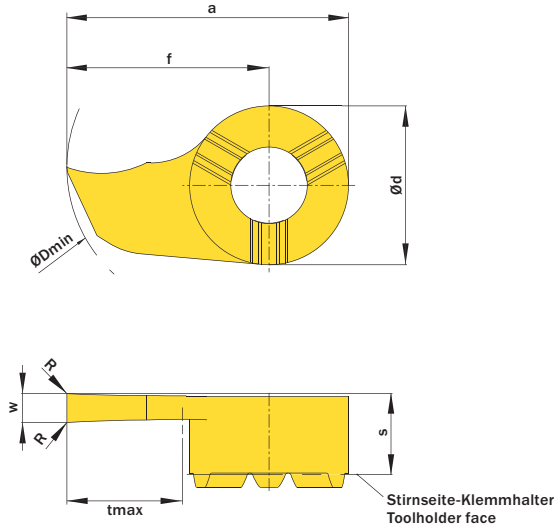

w ^{+0,03}	Nutnenbreite Nominal width of groove	ØDmin (Min. Bohrung) ØDmin (min. bore)	Artikelnummer Part number	Webcode www.simtek.com/webcode	Unsere erste Wahl Our first choice	a	Ød	f	R	S	tmax	Connectcode www.simtek.com/code
mm	mm	mm			P K M N S	mm	mm	mm	mm	mm	mm	

Fortgesetzte Tabelle Continued Table **Verwandte Werkzeuge finden Sie auch auf der vorhergehenden Seite!**
Related items can be found on the previous page as well!

1,5	-	20,0	D18.0150.00.20 GR/L	R AMAQ L AB14	X800 X400	19,5	11,0	14,0	-	5,6	8,0	D18
2,0	-	20,0	D18.0200.00.20 GR/L	R AM2K L AMM9	X800 X400	19,5	11,0	14,0	-	5,6	8,0	D18
2,388	-	20,0	D18.0238.00.20 GR/L	R A1D3 L A1D2	X800 X400	19,5	11,0	14,0	-	5,6	8,0	D18
2,5	-	20,0	D18.0250.00.20 GR/L	R ADCV L AABA	X800 X400	19,5	11,0	14,0	-	5,6	8,0	D18
3,0	-	20,0	D18.0300.00.20 GR/L	R AF2Q L AEJG	X800 X400	19,5	11,0	14,0	-	5,6	8,0	D18
3,5	-	20,0	D18.0350.00.20 GR/L	R AJSF L AEH4	X800 X400	19,5	11,0	14,0	-	5,6	8,0	D18
4,0	-	20,0	D18.0400.00.20 GR/L	R AMJZ L AEAS	X800 X400	19,5	11,0	14,0	-	5,6	8,0	D18

Bestellbeispiel // Order example: **D18.0300.00.20 GR X800** (R = Rechte Ausführung // Right hand version, X800 = Schneidstoff // Grade)



D18. w, 1/100 mm, 4 Stellen/Digits . R, 1/100 mm, 3 Stellen/Digits .20 Toleranz // Tolerance R/L
Beispielartikelnummer // Example Part number: **D18.0156.015.20 XN R** oder/ or **D18.0156.015.20 XN L**