

# Nutenstechen

Geeignet ab Bohrungsdurchmesser 5,2 mm.

# Grooving

For use in bores as of minimum bore diameter 5,2 mm.

Schnittwerte (Start) // Cutting parameters (start)

f	Vc
0,02 mm/U	Seite/Page 429

Passende Klemmhalter auf Seite // Suitable toolholders on page

27, 31, 33, 35, 41, 44, 50, 51, 53,  
55, 56, 57, 61, 62, 63, 65, 66, 67,  
68, 69

Vergleichbare Werkzeuge auf Seite // Similar tools on page

102



Legende  
Legend 139

Scan QR-Code Oder besuchen Sie // Or Visit  
[www.simtek.info/cp/794](http://www.simtek.info/cp/794)

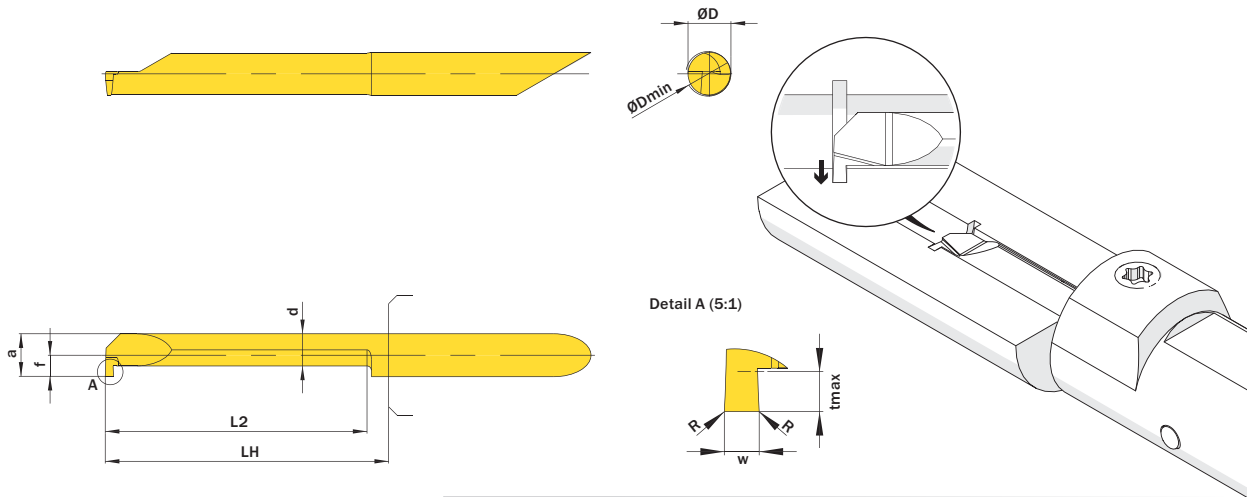

Mehr Informationen zur Kühlmittelzufuhr finden Sie auf Seite 22  
Additional information about through coolant supply on page 22

ØD	w <sup>+0,03</sup>	L2	ØDmin (Min. Bohrung) ØDmin (min. bore)	Kühlmittelzufuhr Through coolant supply	Artikelnummer Part number	Webcode www.simtek.com/webcode	Unsere erste Wahl Our first choice	a	d	f	LH	R	tmax	Connectcode www.simtek.com/code
mm	mm	mm	mm				P K M N S	mm	mm	mm	mm	mm	mm	

Fortgesetzte Tabelle  
Continued Table

Verwandte Werkzeuge finden Sie auch auf der vorhergehenden Seite!  
Related Items can be found on the previous page as well!

▼ w = 0,787 mm																				
5,0	0,787	10,2	5,2	+	A05.0078.10.52 GR/L	R AD73	L ADME	X800	X400	4,95	3,75	2,45	13,0	-	1,0	R	A05.R	L	A05.L	inch
5,0	0,787	15,2	5,2	+	A05.0078.15.52 GR/L	R AKYB	L ANF8	X800	X400	4,95	3,75	2,45	18,0	-	1,0	R	A05.R	L	A05.L	inch
5,0	0,787	20,3	5,2	+	A05.0078.20.52 GR/L	R ANXZ	L AE12	X800	X400	4,95	3,75	2,45	23,0	-	1,0	R	A05.R	L	A05.L	inch
5,0	0,787	25,4	5,2	+	A05.0078.25.52 GR/L	R AHZ2	L AG9U	X800	X400	4,95	3,75	2,45	28,0	-	1,0	R	A05.R	L	A05.L	inch
5,0	0,787	30,5	5,2	+	A05.0078.30.52 GR/L	R ADYH	L AFFQ	X800	X400	4,95	3,75	2,45	33,0	-	1,0	R	A05.R	L	A05.L	inch
5,0	0,787	35,6	5,2	+	A05.0078.35.52 GR/L	R AGMP	L ACT2	X800	X400	4,95	3,75	2,45	38,0	-	1,0	R	A05.R	L	A05.L	inch
▼ w = 1,0 mm																				
5,0	1,0	10,2	5,2	+	A05.0100.10.52 GR/L	R AEBC	L AFST	X800	X400	4,95	3,75	2,45	13,0	-	1,0	R	A05.R	L	A05.L	inch
5,0	1,0	15,2	5,2	+	A05.0100.15.52 GR/L	R ADK5	L AA5P	X800	X400	4,95	3,75	2,45	18,0	-	1,0	R	A05.R	L	A05.L	inch
5,0	1,0	20,3	5,2	+	A05.0100.20.52 GR/L	R AAXA	L AH69	X800	X400	4,95	3,75	2,45	23,0	-	1,0	R	A05.R	L	A05.L	inch
5,0	1,0	25,4	5,2	+	A05.0100.25.52 GR/L	R AGA3	L ADBV	X800	X400	4,95	3,75	2,45	28,0	-	1,0	R	A05.R	L	A05.L	inch
5,0	1,0	30,5	5,2	+	A05.0100.30.52 GR/L	R AKAP	L AHB5	X800	X400	4,95	3,75	2,45	33,0	-	1,0	R	A05.R	L	A05.L	inch
5,0	1,0	35,6	5,2	+	A05.0100.35.52 GR/L	R ABCY	L AMGE	X800	X400	4,95	3,75	2,45	38,0	-	1,0	R	A05.R	L	A05.L	inch
▼ w = 1,168 mm																				
5,0	1,168	10,2	5,2	+	A05.0117.10.52 GR/L	R AGK0	L AFMN	X800	X400	4,95	3,75	2,45	13,0	-	1,0	R	A05.R	L	A05.L	inch
5,0	1,168	15,2	5,2	+	A05.0117.15.52 GR/L	R AKC3	L APGJ	X800	X400	4,95	3,75	2,45	18,0	-	1,0	R	A05.R	L	A05.L	inch
5,0	1,168	20,3	5,2	+	A05.0117.20.52 GR/L	R AF9G	L AGZA	X800	X400	4,95	3,75	2,45	23,0	-	1,0	R	A05.R	L	A05.L	inch
5,0	1,168	25,4	5,2	+	A05.0117.25.52 GR/L	R AKW7	L AAG8	X800	X400	4,95	3,75	2,45	28,0	-	1,0	R	A05.R	L	A05.L	inch
5,0	1,168	30,5	5,2	+	A05.0117.30.52 GR/L	R ACS4	L AHK1	X800	X400	4,95	3,75	2,45	33,0	-	1,0	R	A05.R	L	A05.L	inch
5,0	1,168	35,6	5,2	+	A05.0117.35.52 GR/L	R AJH3	L ADGE	X800	X400	4,95	3,75	2,45	38,0	-	1,0	R	A05.R	L	A05.L	inch

Verwandte Werkzeuge finden Sie auch auf der folgenden Seite!  
Related Items can be found on the following page as well!

Fortgesetzte Tabelle  
Continued Table

Bestellbeispiel // Order example: A05.0100.15.52 GR X800 (R = Rechte Ausführung // Right hand version, X800 = Schneidstoff // Grade)



A05. w, 1/100 mm, 3 Stellen/Digits . L2, 1/1 mm, 2 Stellen/Digits .52. R, 1/100 mm, 3 Stellen/Digits Toleranz // Tolerance R/L  
Beispielartikelnummer // Example Part number: A05.137.15.52.015 XN R oder//or A05.137.15.52.015 XN L