

Fräsen von Vollradiusnuten

Nutfräsen runder Nutformen.
Geeignet ab Bohrungsdurchmesser 22,0 mm.

Full Radius Groove Milling

Full radius groove milling.
For use in bores as of minimum bore diameter 22,0 mm.

Schnittwerte (Start) // Cutting parameters (start)

fzm 0,04 mm	hmax 0,05 mm	Vc Seite/Page 638
-----------------------	------------------------	-----------------------------

Passende Klemmhalter auf Seite // Suitable toolholders on page
556, 557, 558, 559, 560, 561, 562, 563, 564

Vergleichbare Werkzeuge auf Seite // Similar tools on page
465

Bitte Hinweise im Anhang beachten // Please read add. notes
ALL (Seite/Page 645), H01 (Seite/Page 646)



SP Legende
HM Legend **650**



Scan QR-Code Oder besuchen Sie // Or Visit
www.simtek.info/cp/403

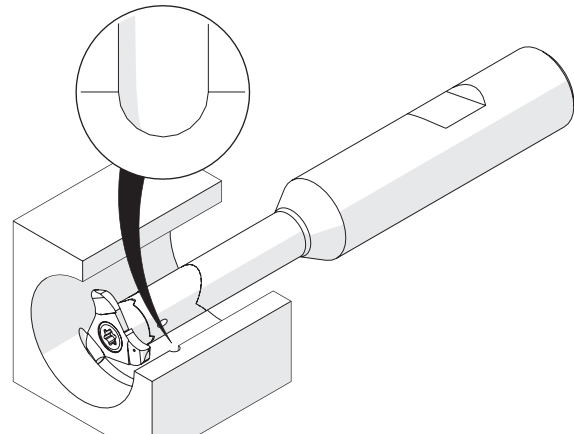
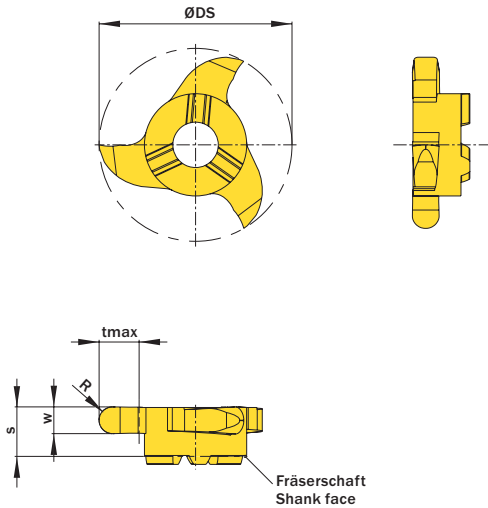

Illustration zeigt beispielhafte Anwendungsmöglichkeit mit ähnlichem Werkzeug.
Image shows exemplary application possibility with similar tool.

Abbildung zeigt / Drawing shows: V22.0015.30 V

R	w ^{+0,03}	ØDmin (Min. Bohrung) ØDmin (min. bore)	Artikelnummer Part number	Webcode www.simtek.com/webcode	Unsere erste Wahl Our first choice		tmax	S	ØDS	Anzahl Schneiden Number of cutting edges	Connectcode www.simtek.com/code
					P	M					
0,5	1,0	22,0	V22.0005.10 V	AD2W	X800	GT42	4,5	5,8	21,7	3	VD12.0
0,8	1,6	22,0	V22.0008.16 V	AFEE	X800	GT42	4,5	5,8	21,7	3	VD12.0
1,0	2,0	22,0	V22.0010.20 V	ABHY	X800	GT42	4,5	5,8	21,7	3	VD12.0
1,2	2,4	22,0	V22.0012.24 V	ACH9	X800	GT42	4,5	5,8	21,7	3	VD12.0
1,4	2,8	22,0	V22.0014.28 V	ADDY	X800	GT42	4,5	5,8	21,7	3	VD12.0
1,5	3,0	22,0	V22.0015.30 V	AF96	X800	GT42	4,5	5,8	21,7	3	VD12.0
1,588	3,175	22,0	V22.0062.12 V	A3T5	X800	GT42	4,5	5,8	21,7	3	VD12.0 <small>new inch</small>
2,2	4,4	22,0	V22.0022.44 V	AC2Y	X800	GT42	4,5	5,8	21,7	3	VD12.0
2,381	4,762	22,0	V22.0024.48 V	A38X	X800	GT42	4,5	5,8	21,7	3	VD12.0 <small>new inch</small>
2,5	5,0	22,0	V22.0025.50 V	AH32	X800	GT42	4,5	5,8	21,7	3	VD12.0
3,2	6,4	22,0	V22.0032.64 V	A1E0	X800	GT42	4,5	9,3	21,7	3	VD12.0
1,588	3,175	25,0	V25.0016.318 V	A6U9	X800	GT42	5,0	6,6	24,7	3	VD12.0 <small>new inch</small>
1,588	3,175	28,0	V28.0016.318 V	A61V	X800	GT42	6,5	6,6	27,7	3	VD12.0 <small>new inch</small>
3,175	6,35	28,0	V28.0032.635 V	A6X7	X800	GT42	6,5	6,6	27,7	3	VD12.0 <small>new inch</small>

Bestellbeispiel // Order example: **V22.0014.28 V X800** (X800 = Schneidstoff // Grade)