

Kopieren / Profildrehen mit 47°

Geeignet ab Bohrungsdurchmesser 7,0 mm.

Copying / Profiling with 47°

For use in bores as of minimum bore diameter 7,0 mm.

Schnittwerte (Start) // Cutting parameters (start)

f **0,02 mm/U** Vc **Seite/Page 429**

Passende Klemmhalter auf Seite // Suitable toolholders on page

153, 154, 155, 156, 157, 158, 159, 160, 161, 162, 163, 164



Legende **213**
Legend



Oder besuchen Sie // Or Visit
www.simtek.info/cp/814

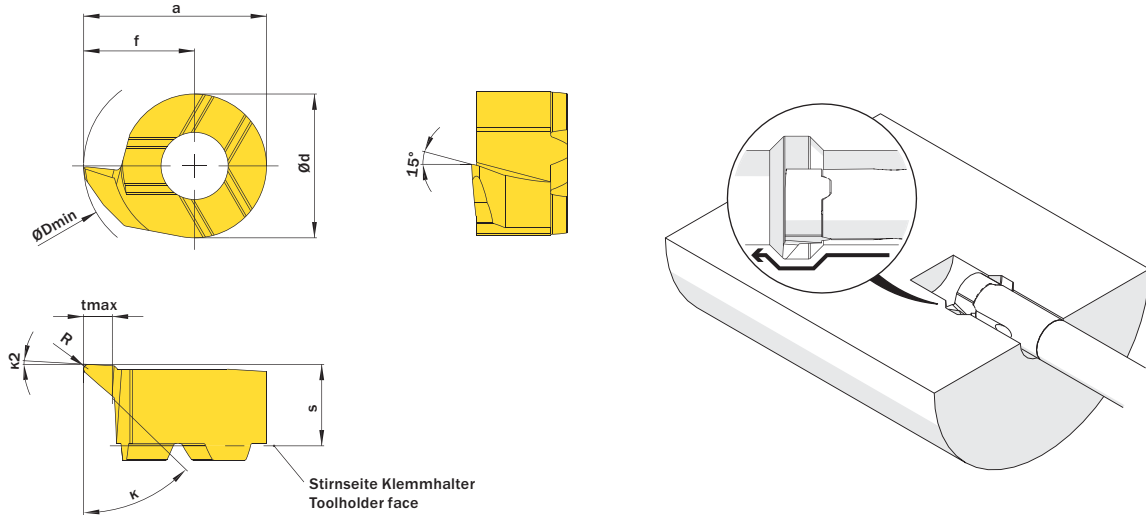

Abbildung zeigt / Drawing shows: D08.4746.02 Y R

| ØDmin (Min. Bohrung) ØDmin (min. bore) | κ | κ2 | f | R | Artikelnummer Part number | Webcode www.simtek.com/webcode | Unsere erste Wahl Our first choice | a | Ød | S | tmax | Connectcode www.simtek.com/code |
|--|-----|----|------|-----|------------------------------|-----------------------------------|---------------------------------------|------|------|-----|------|------------------------------------|
| mm | | | mm | mm | | | P K M N S | mm | mm | mm | mm | |
| ▼ ØDmin (Min. Bohrung) // ØDmin (min. bore) = 7,0 mm | | | | | | | | | | | | |
| 7,0 | 47° | 3° | 4,15 | 0,2 | D07.4746.02 YR/L | R AVQU L AXBB | X800 X400 | 6,55 | 4,8 | 3,7 | 1,2 | D07 |
| ▼ ØDmin (Min. Bohrung) // ØDmin (min. bore) = 7,8 mm | | | | | | | | | | | | |
| 7,8 | 47° | 3° | 4,65 | 0,1 | D08.4746.01 YR/L | R AX66 L AX67 | X800 X400 | 7,65 | 6,0 | 3,5 | 1,2 | D08 |
| 7,8 | 47° | 3° | 4,65 | 0,2 | D08.4746.02 YR/L | R AKYF L AJ2X | X800 X400 | 7,65 | 6,0 | 3,5 | 1,2 | D08 |
| 7,8 | 47° | 3° | 4,65 | 0,4 | D08.4746.04 YR/L | R AS6C L AS6D | X800 X400 | 7,65 | 6,0 | 3,5 | 1,2 | D08 |
| ▼ ØDmin (Min. Bohrung) // ØDmin (min. bore) = 9,0 mm | | | | | | | | | | | | |
| 9,0 | 47° | 3° | 5,5 | 0,2 | D09.4755.02.09 YR/L | R AWGJ L AWHZ | X800 X400 | 8,6 | 6,2 | 3,6 | 1,5 | D09 |
| ▼ ØDmin (Min. Bohrung) // ØDmin (min. bore) = 10,0 mm | | | | | | | | | | | | |
| 10,0 | 47° | 3° | 5,8 | 0,2 | D10.4758.02.10 YR/L | R AD29 L AJQD | X800 X400 | 9,3 | 7,0 | 3,9 | 1,8 | D10 |
| ▼ ØDmin (Min. Bohrung) // ØDmin (min. bore) = 11,0 mm | | | | | | | | | | | | |
| 11,0 | 47° | 3° | 6,7 | 0,2 | D11.4767.02 YR/L | R AENC L AA5D | X800 X400 | 10,7 | 8,0 | 4,2 | 2,3 | D11 |
| 11,0 | 47° | 3° | 6,7 | 0,4 | D11.4767.04 YR | A232 | X800 X400 | 10,7 | 8,0 | 4,2 | 2,3 | D11 |
| ▼ ØDmin (Min. Bohrung) // ØDmin (min. bore) = 13,7 mm | | | | | | | | | | | | |
| 13,7 | 47° | 3° | 8,7 | 0,2 | D14.4787.02 YR/L | R AB9M L ACMV | X800 X400 | 13,2 | 9,0 | 5,3 | 4,0 | D14 |
| 13,7 | 47° | 3° | 8,7 | 0,4 | D14.4787.04 YR | A233 | X800 X400 | 13,2 | 9,0 | 5,3 | 4,0 | D14 |
| ▼ ØDmin (Min. Bohrung) // ØDmin (min. bore) = 15,8 mm | | | | | | | | | | | | |
| 15,8 | 47° | 3° | 10,2 | 0,2 | D16.4702.02 YR/L | R AEPV L APDF | X800 X400 | 15,7 | 11,0 | 5,4 | 4,3 | D16 |
| ▼ ØDmin (Min. Bohrung) // ØDmin (min. bore) = 16,0 mm | | | | | | | | | | | | |
| 16,0 | 47° | 3° | 11,0 | 0,2 | D14.4710.02 YR/L | R ANK4 L AAN6 | X800 X400 | 15,5 | 9,0 | 5,2 | 5,0 | D14 |
| ▼ ØDmin (Min. Bohrung) // ØDmin (min. bore) = 18,0 mm | | | | | | | | | | | | |
| 18,0 | 47° | 3° | 12,0 | 0,2 | D18.4712.02.18 YR/L | R ADMT L ANKX | X800 X400 | 17,5 | 11,0 | 5,6 | 6,0 | D18 |
| ▼ ØDmin (Min. Bohrung) // ØDmin (min. bore) = 20,0 mm | | | | | | | | | | | | |
| 20,0 | 47° | 3° | 14,0 | 0,2 | D18.4714.02.20 YR/L | R AE0B L ABFF | X800 X400 | 19,5 | 11,0 | 5,6 | 8,0 | D18 |

Bestellbeispiel // Order example: **D09.4755.02.09 YR X800** (R = Rechte Ausführung // Right hand version, X800 = Schneidstoff // Grade)