

Ausdrehen, Hartbearbeitung und WIPER-Geometrie

In Verbindung mit einem CBN-Schneidstoff besonders geeignet für die Hartbearbeitung ab Bohrungsdurchmesser 2,7 mm.

Boring, Hard Part Turning plus WIPER-Geometry

First choice for hard part turning applications in bores as of bore diameter 2,7 mm in combination with our CBN grades.

Schnittwerte (Start) // Cutting parameters (start)	
f 0,02 mm/U	Vc Seite/Page 429

Passende Klemmhalter auf Seite // Suitable toolholders on page 26, 31, 32, 33, 34, 40, 41, 43, 50, 51, 53, 55, 56, 57, 60, 62, 63, 65, 66, 67, 68, 69

Vergleichbare Werkzeuge auf Seite // Similar tools on page 88

SP
CBN **R**

Legende Legend **139**

Scan QR-Code Oder besuchen Sie // Or visit www.simtek.info/cp/1052

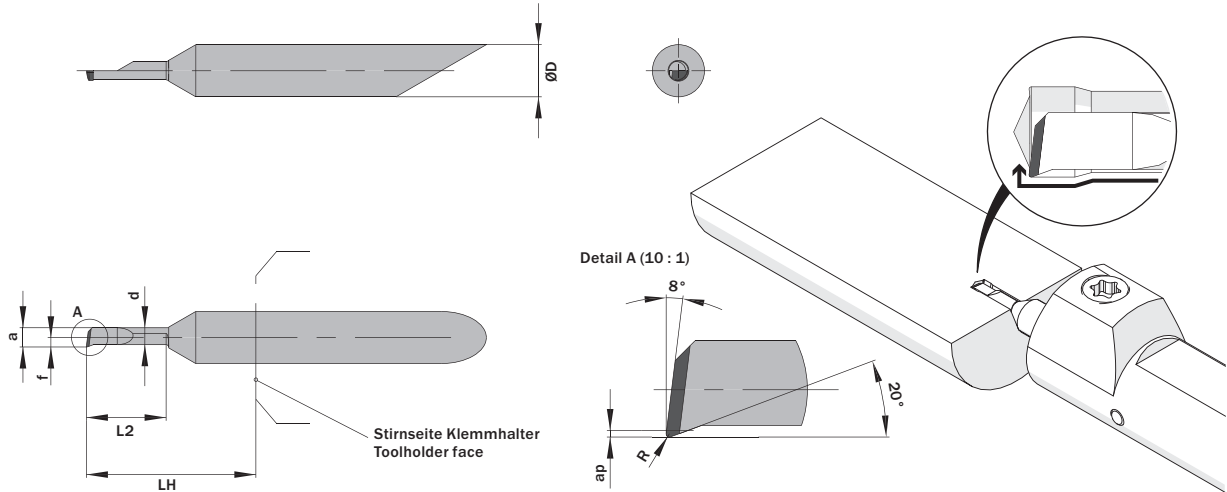

Mehr Informationen zur Kühlmittelzufuhr finden Sie auf Seite 22
Additional information about through coolant supply on page 22

ØD	L2	ØDmin (Min. Bohrung) ØDmin (min. bore)	R	Kühlmittelzufuhr Through coolant supply	Artikelnummer Part number	Webcode www.simtek.com/webcode	Unsere erste Wahl Our first choice	a	ap	d	f	LH	Connectcode www.simtek.com/code
mm	mm	mm	mm				H	mm	mm	mm	mm	mm	

Fortgesetzte Tabelle Continued Table **Verwandte Werkzeuge finden Sie auch auf der vorhergehenden Seite!**
Related items can be found on the previous page as well!

▼ ØDmin (Min. Bohrung) // ØDmin (min. bore) = 2,7 mm													
4,0	10,2	2,7	0,15	-	A04.1812.10.27.15 YUR/L	R AKDS L ADHA	CBN	2,45	0,13	2,05	1,2	13,0	R A04.R L A04.L
4,0	10,2	2,7	0,15	+	A04.1C12.10.27.15 YUR/L	R APSV L ACU3	CBN	2,45	0,13	2,05	1,95	13,0	R A04C.R L A04C.L
4,0	15,2	2,7	0,15	-	A04.1812.15.27.15 YUR/L	R AWK9 L AW4X	CBN	2,45	0,13	2,05	1,2	18,0	R A04.R L A04.L
4,0	15,2	2,7	0,15	+	A04.1C12.15.27.15 YUR/L	R AAQ6 L AG95	CBN	2,45	0,13	2,05	1,95	18,0	R A04C.R L A04C.L
▼ ØDmin (Min. Bohrung) // ØDmin (min. bore) = 3,0 mm													
4,0	15,2	3,0	0,15	-	A04.1814.15.30.15 YUR	A54D	CBN	2,75	0,1	2,35	1,35	23,0	A04.R new
4,0	15,2	3,0	0,15	+	A04.1C14.15.30.15 YUR/L	R AW4C L AW4B	CBN	2,75	0,1	2,35	1,95	23,0	R A04C.R L A04C.L
4,0	20,3	3,0	0,15	-	A04.1814.20.30.15 YUR	A54F	CBN	2,75	0,1	2,35	1,35	23,0	A04.R new
4,0	20,3	3,0	0,15	+	A04.1C14.20.30.15 YUR/L	R AGYZ L ANDP	CBN	2,75	0,1	2,35	1,95	23,0	R A04C.R L A04C.L
▼ ØDmin (Min. Bohrung) // ØDmin (min. bore) = 3,2 mm													
4,0	10,2	3,2	0,15	-	A04.1815.10.32.15 YUR/L	R ADD4 L AB88	CBN	2,95	0,16	2,55	1,45	13,0	R A04.R L A04.L
4,0	10,2	3,2	0,15	+	A04.1C15.10.32.15 YUR/L	R APBY L ABA4	CBN	2,95	0,16	2,55	1,95	13,0	R A04C.R L A04C.L
4,0	15,2	3,2	0,15	-	A04.1815.15.32.15 YUR/L	R AGGV L AJV6	CBN	2,95	0,16	2,55	1,45	18,0	R A04.R L A04.L
4,0	15,2	3,2	0,15	+	A04.1C15.15.32.15 YUR/L	R APHK L AFG3	CBN	2,95	0,16	2,55	1,95	18,0	R A04C.R L A04C.L
4,0	20,3	3,2	0,15	-	A04.1815.20.32.15 YUR/L	R AQ5Q L ATT2	CBN	2,95	0,16	2,55	1,45	23,0	R A04.R L A04.L
4,0	20,3	3,2	0,15	+	A04.1C15.20.32.15 YUR/L	R AHC2 L AD09	CBN	2,95	0,16	2,55	1,95	23,0	R A04C.R L A04C.L

Verwandte Werkzeuge finden Sie auch auf der folgenden Seite!
Related items can be found on the following page as well!

Fortgesetzte Tabelle Continued Table

Bestellbeispiel // Order example: **A04.1815.10.32.15 YUR CBN8** (R = Rechte Ausführung // Right hand version, CBN8 = Schneidstoff // Grade)