

Stechen von Vollradiusnuten

Geeignet ab Bohrungsdurchmesser 4,2 mm.

Full Radius Grooving

For use in bores as of minimum bore diameter 4,2 mm.

Schnittwerte (Start) // Cutting parameters (start)

| | |
|-----------|----------------|
| f | Vc |
| 0,02 mm/U | Seite/Page 429 |

Passende Klemmhalter auf Seite // Suitable toolholders on page

27, 28, 31, 32, 33, 34, 35, 36, 40,
41, 42, 43, 44, 45, 50, 51, 53, 55,
56, 57, 58, 60, 61, 62, 63, 64, 65,
66, 67, 68, 69



SP HM R
Legende Legend 139

Scan QR-Code Oder besuchen Sie // Or Visit
www.simtek.info/cp/778



Abbildung zeigt / Drawing shows: A06.0150.25.62 VR

Mehr Informationen zur Kühlmittelzufuhr finden Sie auf Seite 22
Additional information about through coolant supply on page 22

| ØD | w ^{+0,03} | L2 | ØDmin (Min. Bohrung) ØDmin (min. bore) | Kühlmittelzufuhr Through coolant supply | Artikelnummer Part number | Webcode www.simtek.com/webcode | Unsere erste Wahl Our first choice | a | d | f | LH | R | tmax | Connectcode www.simtek.com/code |
|----------------------|--------------------|------|---|--|------------------------------|---|---------------------------------------|------|------|------|------|------|------|---|
| mm | mm | mm | mm | | | | P K M N S | mm | mm | mm | mm | mm | mm | |
| ▼ ØD = 4,0 mm | | | | | | | | | | | | | | |
| 4,0 | 1,0 | 15,2 | 4,2 | + | A04.0100.15.42 VR/L | R AC9G L ACXS | X800 X400 | 3,95 | 2,95 | 1,95 | 18,0 | 0,5 | 0,8 | R A04C.R L A04C.L |
| 4,0 | 1,168 | 15,2 | 4,2 | + | A04.0117.15.42 VR/L | R AG4M L AGZT | X800 X400 | 3,95 | 2,95 | 1,95 | 18,0 | 0,58 | 0,8 | R A04C.R L A04C.L inch |
| ▼ ØD = 5,0 mm | | | | | | | | | | | | | | |
| 5,0 | 1,0 | 20,3 | 5,2 | + | A05.0100.20.52 VR/L | R AHPY L AMKU | X800 X400 | 4,95 | 3,75 | 2,45 | 23,0 | 0,5 | 1,0 | R A05.R L A05.L |
| 5,0 | 1,168 | 20,3 | 5,2 | + | A05.0117.20.52 VR/L | R AGGW L AFDM | X800 X400 | 4,95 | 3,75 | 2,45 | 23,0 | 0,58 | 1,0 | R A05.R L A05.L inch |
| 5,0 | 1,5 | 20,3 | 5,2 | + | A05.0150.20.52 VR/L | R AA2S L ACC3 | X800 X400 | 4,95 | 3,75 | 2,45 | 23,0 | 0,75 | 1,0 | R A05.R L A05.L |
| 5,0 | 1,575 | 20,3 | 5,2 | + | A05.0157.20.52 VR/L | R AM8X L APCC | X800 X400 | 4,95 | 3,75 | 2,45 | 23,0 | 0,79 | 1,0 | R A05.R L A05.L inch |
| 5,0 | 1,626 | 20,3 | 5,2 | + | A05.0163.20.52 VR/L | R AT8E L AT8D | X800 X400 | 4,95 | 3,75 | 2,45 | 23,0 | 0,81 | 1,0 | R A05.R L A05.L inch |
| 5,0 | 1,981 | 20,3 | 5,2 | + | A05.0198.20.52 VR/L | R AT8G L AT8F | X800 X400 | 4,95 | 3,75 | 2,45 | 23,0 | 0,99 | 1,0 | R A05.R L A05.L inch |
| 5,0 | 2,0 | 20,3 | 5,2 | + | A05.0200.20.52 VR/L | R AK1U L AMG6 | X800 X400 | 4,95 | 3,75 | 2,45 | 23,0 | 1,0 | 1,0 | R A05.R L A05.L |
| ▼ ØD = 6,0 mm | | | | | | | | | | | | | | |
| 6,0 | 1,0 | 25,4 | 6,2 | + | A06.0100.25.62 VR/L | R AKUZ L AFNY | X800 X400 | 5,95 | 3,95 | 2,95 | 28,0 | 0,5 | 1,8 | R A06.R L A06.L |
| 6,0 | 1,168 | 25,4 | 6,2 | + | A06.0117.25.62 VR/L | R AKMZ L AGQY | X800 X400 | 5,95 | 3,95 | 2,95 | 28,0 | 0,58 | 1,8 | R A06.R L A06.L inch |
| 6,0 | 1,5 | 25,4 | 6,2 | + | A06.0150.25.62 VR/L | R AD22 L AMMJ | X800 X400 | 5,95 | 3,95 | 2,95 | 28,0 | 0,75 | 1,8 | R A06.R L A06.L |
| 6,0 | 1,575 | 25,4 | 6,2 | + | A06.0157.25.62 VR/L | R APSG L ANCZ | X800 X400 | 5,95 | 3,95 | 2,95 | 28,0 | 0,79 | 1,8 | R A06.R L A06.L inch |
| 6,0 | 1,626 | 25,4 | 6,2 | + | A06.0163.25.62 VR/L | R AT8J L AT8H | X800 X400 | 5,95 | 3,95 | 2,95 | 28,0 | 0,81 | 1,8 | R A06.R L A06.L inch |
| 6,0 | 1,981 | 25,4 | 6,2 | + | A06.0198.25.62 VR/L | R AT8M L AT8K | X800 X400 | 5,95 | 3,95 | 2,95 | 28,0 | 0,99 | 1,8 | R A06.R L A06.L inch |
| 6,0 | 2,0 | 20,3 | 6,2 | + | A06.0200.20.62 VR/L | R AMVK L AFV9 | X800 X400 | 5,95 | 3,95 | 2,95 | 23,0 | 1,0 | 1,8 | R A06.R L A06.L |
| 6,0 | 2,0 | 25,4 | 6,2 | + | A06.0200.25.62 VR/L | R AH3S L AKZ8 | X800 X400 | 5,95 | 3,95 | 2,95 | 28,0 | 1,0 | 1,8 | R A06.R L A06.L |

Verwandte Werkzeuge finden Sie auch auf der folgenden Seite!
Related Items can be found on the following page as well!

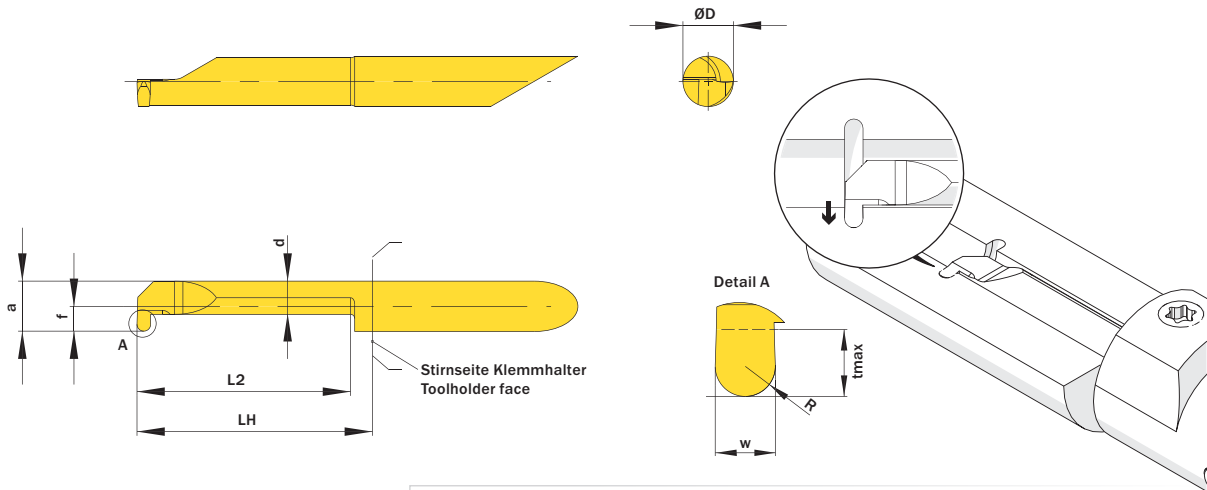
Fortgesetzte Tabelle
Continued Table

Bestellbeispiel // Order example: A06.0200.25.62 VR X800 (R = Rechte Ausführung // Right hand version, X800 = Schneidstoff // Grade)