

Gewindedrehen, Metrisches ISO Teilprofil

Mehrbereichswerkzeuge für verschiedene Steigungen.

Threading, Metric ISO Partial Profile

Multi-purpose tools, usable for different pitches.

Schnittwerte (Start) // Cutting parameters (start)
Anzahl Durchgänge // Number of passes 10 - 16
Empf. Zustellungsart // Recom. infeed method Flankenzustellung // Flank infeed (Seite/Page 433)
Vc Seite/Page 429

Passende Klemmhalter auf Seite // Suitable toolholders on page
157, 158, 159, 161, 163, 164

SP

HM

Scan QR-Code

Legende
Legend **213**

Oder besuchen Sie // Or Visit
www.simtek.info/cp/881



Abbildung zeigt / Drawing shows: D14.1020.01 M R

Steigung (von) Pitch (as of)	Steigung (bis) Pitch (up to)	Artikelnummer Part number	Webcode www.simtek.com/webcode	Unsere erste Wahl Our first choice	a	t	b	Ød	ØDmin (Min. Bohrung) ØDmin (min. bore)	f	S	w	Connectcode www.simtek.com/code
mm	mm			P K M N S	mm	mm	mm	mm	mm	mm	mm	mm	

Fortgesetzte Tabelle Continued Table

Verwandte Werkzeuge finden Sie auch auf der vorhergehenden Seite! Related items can be found on the previous page as well!

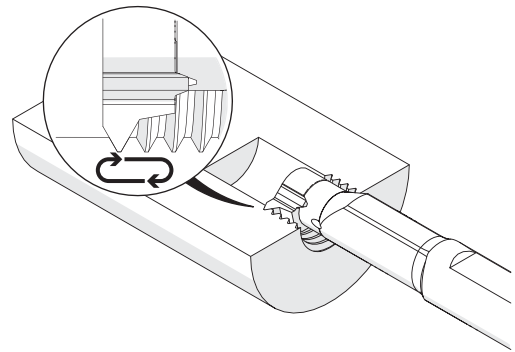
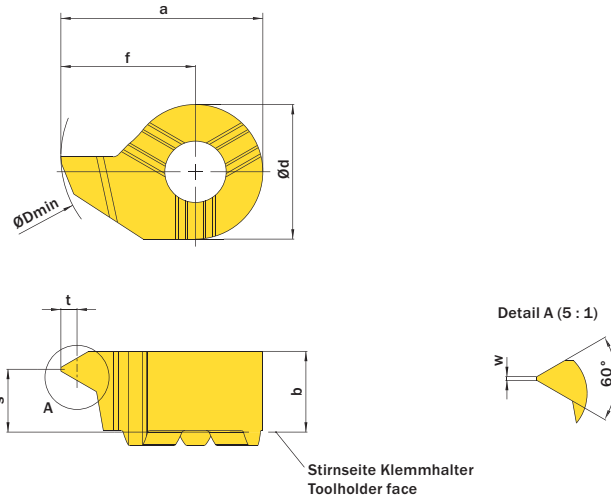
▼ ØDmin (Min. Bohrung) // ØDmin (min. bore) = 11,0 mm																	
0,5	0,75	D11.0205.01 MR/L	R	AJEC	L	ANKC	X800	X400	10,7	0,43	4,2	8,0	11,0	6,7	3,75	0,06	D11
1,0	1,25	D11.0510.01 MR/L	R	ABSH	L	ACPA	X800	X400	10,7	0,7	4,2	8,0	11,0	6,7	3,6	0,12	D11
1,5	1,75	D11.0815.01 MR/L	R	AGA9	L	AC8F	X800	X400	10,7	0,98	4,2	8,0	11,0	6,7	3,2	0,18	D11 upd
2,0	2,5	D11.1020.01 MR/L	R	AJ8F	L	AGUB	X800	X400	10,7	1,41	4,2	8,0	11,0	6,7	2,9	0,25	D11 upd
2,5	3,0	D11.1325.01 MR/L	R	AFSG	L	AMNB	X800	X400	10,7	1,68	4,2	8,0	11,0	6,7	2,8	0,31	D11 upd
▼ ØDmin (Min. Bohrung) // ØDmin (min. bore) = 14,0 mm																	
1,0	1,25	D14.0510.01 MR/L	R	AAYN	L	AJ9C	X800	X400	13,5	0,55	5,4	9,0	14,0	9,0	4,6	0,12	D14
1,5	1,75	D14.0815.01 MR/L	R	AM9F	L	ADYM	X800	X400	13,5	0,81	5,4	9,0	14,0	9,0	4,3	0,18	D14
2,0	2,5	D14.1020.01 MR/L	R	AEQN	L	AA41	X800	X400	13,5	1,08	5,4	9,0	14,0	9,0	3,9	0,25	D14
2,5	3,0	D14.1325.01 MR/L	R	APM1	L	AEX9	X800	X400	13,5	1,35	5,4	9,0	14,0	9,0	3,55	0,31	D14
▼ ØDmin (Min. Bohrung) // ØDmin (min. bore) = 16,0 mm																	
1,0	1,25	D16.0510.01 MR/L	R	AFMB	L	ACG7	X800	X400	15,7	0,7	5,4	11,0	16,0	10,2	4,8	0,12	D16
1,5	1,75	D16.0815.01 MR/L	R	AFAG	L	ANF1	X800	X400	15,7	0,98	5,4	11,0	16,0	10,2	4,6	0,18	D16
2,0	2,5	D16.1020.01 MR/L	R	AG9J	L	AJDQ	X800	X400	15,7	1,41	5,4	11,0	16,0	10,2	4,35	0,25	D16
2,5	3,0	D16.1325.01 MR/L	R	AKYZ	L	AGDW	X800	X400	15,7	1,68	5,4	11,0	16,0	10,2	4,15	0,31	D16

Bestellbeispiel // Order example: **D11.0815.01 MR X800** (R = Rechte Ausführung // Right hand version, X800 = Schneidstoff // Grade)

Bitte beachten Sie die zusätzlichen Hinweise zu den Mehrbereichswerkzeugen im Infobereich rechts oben.

Please read the additional notes mentioned in the information area on the top right corner of this page.