

Nutenstechen

Geeignet ab Bohrungsdurchmesser 5,2 mm.

Grooving

For use in bores as of minimum bore diameter 5,2 mm.

Schnittwerte (Start) // Cutting parameters (start)

f	Vc
0,02 mm/U	Seite/Page 429

Passende Klemmhalter auf Seite // Suitable toolholders on page

27, 28, 31, 33, 35, 36, 41, 42, 44,
45, 50, 51, 53, 55, 56, 57, 58, 61,
62, 63, 64, 65, 66, 67, 68, 69

Vergleichbare Werkzeuge auf Seite // Similar tools on page
102



Legende
Legend 139



Scan
QR-Code

Oder besuchen Sie // Or Visit
www.simtek.info/cp/796

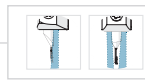
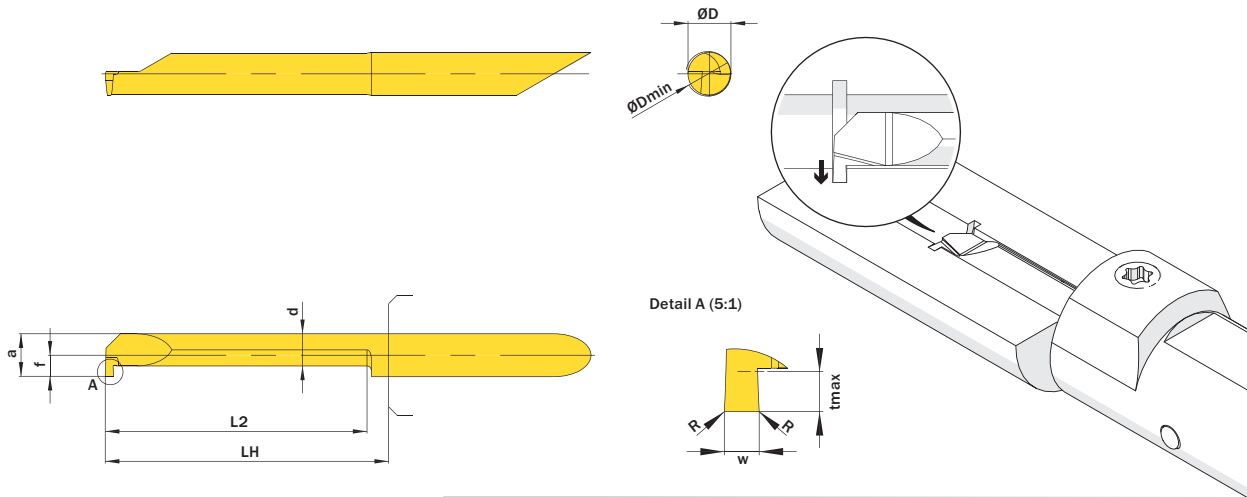

Mehr Informationen zur Kühlmittelzufuhr finden Sie auf Seite 22
Additional information about through coolant supply on page 22

ØD	w ^{+0,03}	L2	ØDmin (Min. Bohrung) ØDmin (min. bore)	Kühlmittelzufuhr Through coolant supply	Artikelnummer Part number	Webcode www.simtek.com/webcode	Unsere erste Wahl Our first choice	a	d	f	LH	R	tmax	Connectcode www.simtek.com/code
mm	mm	mm	mm				P K M N S	mm	mm	mm	mm	mm	mm	

Fortgesetzte Tabelle
Continued Table

Verwandte Werkzeuge finden Sie auch auf der vorhergehenden Seite!
Related items can be found on the previous page as well!

▼ ØD = 5,0 mm														
5,0	2,0	10,2	5,2	+	A05.0200.10.52 GR/L	R AEKP L ABTY X800 X400	4,95	3,75	2,45	13,0	-	1,0	R	A05.R L A05.L
5,0	2,0	15,2	5,2	+	A05.0200.15.52 GR/L	R ACHW L AA3V X800 X400	4,95	3,75	2,45	18,0	-	1,0	R	A05.R L A05.L
5,0	2,0	20,3	5,2	+	A05.0200.20.52 GR/L	R AHTZ L AJX6 X800 X400	4,95	3,75	2,45	23,0	-	1,0	R	A05.R L A05.L
5,0	2,0	25,4	5,2	+	A05.0200.25.52 GR/L	R AMKP L AMNF X800 X400	4,95	3,75	2,45	28,0	-	1,0	R	A05.R L A05.L
5,0	2,0	30,5	5,2	+	A05.0200.30.52 GR/L	R AF7J L AHFX X800 X400	4,95	3,75	2,45	33,0	-	1,0	R	A05.R L A05.L
▼ ØD = 6,0 mm														
6,0	0,787	10,2	6,2	+	A06.0078.10.62 GR/L	R AC9Z L AMAW X800 X400	5,95	3,95	2,95	13,0	-	1,8	R	A06.R L A06.L <small>inch</small>
6,0	0,787	15,2	6,2	+	A06.0078.15.62 GR/L	R AN1C L AGWT X800 X400	5,95	3,95	2,95	18,0	-	1,8	R	A06.R L A06.L <small>inch</small>
6,0	0,787	20,3	6,2	+	A06.0078.20.62 GR/L	R AFQZ L AFX4 X800 X400	5,95	3,95	2,95	23,0	-	1,8	R	A06.R L A06.L <small>inch</small>
6,0	0,787	25,4	6,2	+	A06.0078.25.62 GR/L	R AGDØ L AJZ5 X800 X400	5,95	3,95	2,95	28,0	-	1,8	R	A06.R L A06.L <small>inch</small>
6,0	0,787	30,5	6,2	+	A06.0078.30.62 GR/L	R ACZD L AMXV X800 X400	5,95	3,95	2,95	33,0	-	1,8	R	A06.R L A06.L <small>inch</small>
6,0	0,787	35,6	6,2	+	A06.0078.35.62 GR/L	R ADAE L AKZG X800 X400	5,95	3,95	2,95	38,0	-	1,8	R	A06.R L A06.L <small>inch</small>

Verwandte Werkzeuge finden Sie auch auf der folgenden Seite!
Related items can be found on the following page as well!

Fortgesetzte Tabelle
Continued Table

Bestellbeispiel // Order example: **A06.0078.20.62 GR X800** (R = Rechte Ausführung // Right hand version, X800 = Schneidstoff // Grade)



A05. [w. 1/100 mm, 3 Stellen/Digits](#) . [L2, 1/1 mm, 2 Stellen/Digits](#) .52. [R, 1/100 mm, 3 Stellen/Digits](#) Toleranz // Tolerance R/L
Beispielartikelnummer // Example Part number: **A05.137.15.52.015 XN R** oder/ or **A05.137.15.52.015 XN L**



A05. [w. 1/100 mm, 3 Stellen/Digits](#) . [L2, 1/1 mm, 2 Stellen/Digits](#) .52. [R, 1/100 mm, 3 Stellen/Digits](#) Toleranz // Tolerance R/L
Beispielartikelnummer // Example Part number: **A05.137.15.52.015 XN R** oder/ or **A05.137.15.52.015 XN L**

A06. [w. 1/100 mm, 3 Stellen/Digits](#) . [L2, 1/1 mm, 2 Stellen/Digits](#) .62. [R, 1/100 mm, 3 Stellen/Digits](#) Toleranz // Tolerance R/L
Beispielartikelnummer // Example Part number: **A06.137.15.62.015 XN R** oder/ or **A06.137.15.62.015 XN L**