

Fräserschaft, für Spannzangenfutter (DIN 6499)

Für Spannzangenfutter nach DIN6499-A.

Milling cutter shank, for collet chucks (DIN6499)

For collet chucks according to DIN6499-A.

Anzugsmoment (Schraube) // Tightening torque (screw)

4,5 Nm

Vergleichbare Werkzeuge auf Seite // Similar tools on page
472

Bitte Hinweise im Anhang beachten // Please read add. notes

ALL (Seite/Page 645)



TW
ST

Legende
Legend

650



Scan
QR-Code

Oder besuchen Sie // Or Visit
www.simtek.info/cp/455

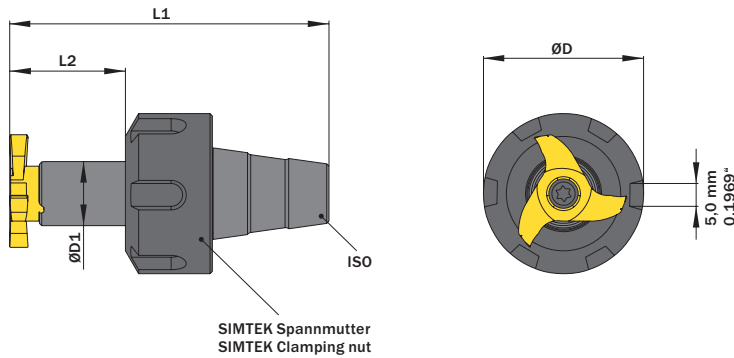

SIMTEK Spannmutter
SIMTEK Clamping nut

Fräserschaft ist nur mit passender Spannmutter verfügbar.
Spannmutter ist auch einzeln als Ersatzteil verfügbar.
Milling cutter shank is only available together with clamping nut.
Clamping nut is available as a spare part.

Für Spannzange For collet chuck	ØD1	L2	Artikelnummer Part number	Webcode www.simtek.com/webcode	Spannmutter Clamping nut	Gewinde Spannmutter Thread clamping nut	ØD	L1	Schraube Screw	Schraubenschlüssel Screw driver	Connectcode www.simtek.com/code
	mm	mm					mm	mm			
ER11	9,0	22,0	U18.ER11.09.22	AAV2	U ER11.12.19	M14x0,75	19,0	42,0	UM4x12 T15F	T15F	UD09.0
ER11	9,0	22,0	U18.ER11.09.22.B	AVMS	U ER11.12.16	M13x0,75	16,0	42,0	UM4x12 T15F	T15F	UD09.0
ER16	9,0	22,0	U18.ER16.09.22	APHJ	U ER16.18.32	M22x1,5	32,0	52,0	UM4x12 T15F	T15F	UD09.0
ER16	9,0	22,0	U18.ER16.09.22.B	AVMV	U ER16.18.22	M19x1,0	22,0	52,0	UM4x12 T15F	T15F	UD09.0
ER16	9,0	22,0	U18.ER16.09.22.C	AVMW	U ER16.18.25	M19x1,0	25,0	52,0	UM4x12 T15F	T15F	UD09.0
ER20	9,0	22,0	U18.ER20.09.22	AC9J	U ER20.19.35	M25x1,5	35,0	56,5	UM4x12 T15F	T15F	UD09.0
ER20	9,0	22,0	U18.ER20.09.22.B	AVM0	U ER20.19.28	M24x1,0	28,0	56,5	UM4x12 T15F	T15F	UD09.0
ER25	9,0	22,0	U18.ER25.09.22	AA1F	U ER25.20.42	M25x1,5	42,0	60,0	UM4x12 T15F	T15F	UD09.0
ER25	9,0	22,0	U18.ER25.09.22.B	AVM3	U ER25.20.35	M30x1,0	35,0	60,0	UM4x12 T15F	T15F	UD09.0

Bestellbeispiel // Order example: **U18.ER16.09.22.B**