

Einstecken

Für allgemeines Nutzenstechen.

Grooving

For general grooving.

Schnittwerte (Start) // Cutting parameters (start)

f	Vc
0,04 mm/U	Seite/Page 429

Passende Klemmhalter auf Seite // Suitable toolholders on page

361, 362, 363, 364, 365, 367, 368

SP Legende

HM Legend

Scan QR-Code

389

Oder besuchen Sie // Or Visit
www.simtek.info/cp/1249

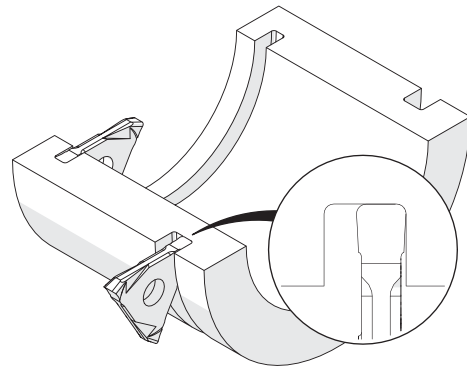
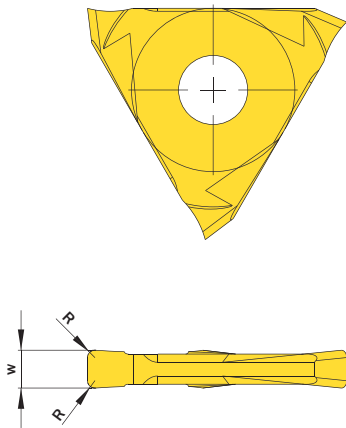

Gewindereife nach DIN 76 Form A auf Anfrage erhältlich. // Thread reliefs according to DIN 76 profile A available upon request.

Abbildung zeigt / Drawing shows: E12.0300.06 N

	w ^{+0,02} mm	R mm	Artikelnummer Part number	Webcode www.simtek.com/webcode	Unsere erste Wahl Our first choice P K M N S	Connectcode www.simtek.com/code	
▼ w = 1,245 mm							
	1,168	-	E12.0117.00 G	AJEW	X800 X400	E12.A1 E12.A2	Inch
▼ w = 1,422 mm							
	1,422	-	E12.0142.00 G	AF62	X800 X400	E12.A1 E12.A2	Inch
▼ w = 1,575 mm							
	1,575	-	E12.0157.00 G	AC0A	X800 X400	E12.A1 E12.A2	Inch
▼ w = 2,388 mm							
	2,388	-	E12.0238.00 G	AFU1	X800 X400	E12.B2	Inch
▼ w = 3,175 mm							
	3,175	-	E12.0318.00 G	ADJ8	X800 X400	E12.C3	Inch

Bestellbeispiel // Order example: **E12.0142.00 G X800** (X800 = Schneidstoff // Grade)