

Axialstechen

Für die Herstellung von Axialnuten.
 Bitte beachten Sie die Freiwinkel.

Face Grooving

For face grooves in different widths.
 Please pay attention to the clearance angles.

Schnittwerte (Start) // Cutting parameters (start)

f (außen//ext.) 0,04 mm/U	Vc Seite/Page 429
------------------------------	----------------------

Passende Klemmhalter auf Seite // Suitable toolholders on page
323, 324, 325, 326, 327, 328

SP
HM

Legende
Legend

354

📱 Scan QR-Code Oder besuchen Sie // Or Visit www.simtek.info/cp/329

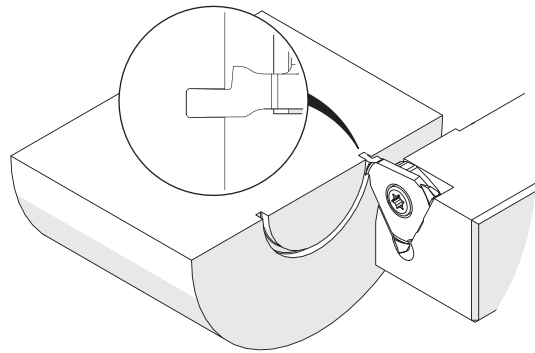
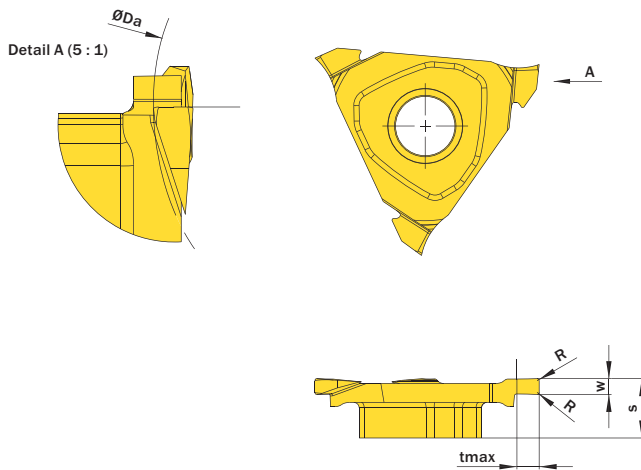

Abbildung zeigt / Drawing shows: TE3.L150.020 AG R

$w \pm 0,02$ mm	R mm	Artikelnummer Part number	Webcode www.simtek.com/webcode	Unsere erste Wahl Our first choice	$\varnothing Da$ mm	S mm	$tmax$ mm	Connectcode www.simtek.com/ccode
				P K M N S				
1,5	0,2	TE3.L150.020 AG R	ABWV	X800 X400	20,0	5,6	2,0	TE3.R.5.3
2,0	0,2	TE3.L200.020 AG R	AACH	X800 X400	30,0	5,6	3,0	TE3.R.5.3
3,0	0,2	TE3.L300.020 AG R	AK3P	X800 X400	30,0	5,6	3,0	TE3.R.5.3

Bestellbeispiel // Order example: **TE3.L200.020 AG R X800** (R = Rechte Ausführung // Right hand version, X800 = Schneidstoff // Grade)

simturn AX
simturn DX
simturn PX
simturn H2
simturn K2
simturn C4
simturn GX
simturn E3
simturn E12
simturn FX
simturn Decolletage
simturn OA
Index