

Abstechen

Verfügbar in verschiedenen Winkeln,
 Breiten und mit/ohne geschliffener Spanformrinne.

Parting Off

Available in different angles,
 widths and with/without ground chip form channel.

Schnittwerte (Start) // Cutting parameters (start)

f	Vc
0,08 mm/U	Seite/Page 429

Passende Klemmhalter auf Seite // Suitable toolholders on page
361, 362, 363, 364, 365, 366, 367, 368

SP

HM

R

Legende
 Legend

389

Oder besuchen Sie // Or Visit
www.simtek.info/cp/513

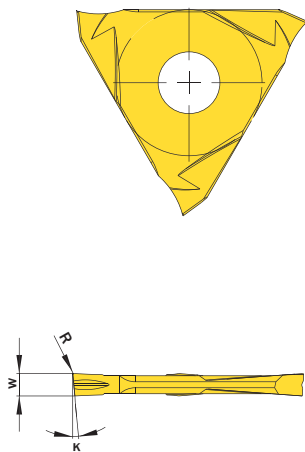

Abbildungen ähnlich // Similar illustrations



E12...00 P R
E12...PS R



E12...11 P R
E12...PT R

! Bearbeitbare Materialien. Siehe unten.
 Machineable materials. See below.



Abbildung zeigt / Drawing shows: E12.1520.11 P R

K	w ^{-0,05} mm	Artikelnummer Part number	Webcode www.simtek.com/webcode	Unsere erste Wahl Our first choice	Mit Spanformrinne With chip form channel	R mm	Connectcode www.simtek.com/ccode
▼ w = 1,0 mm							
12°	1,0	E12.1210.00 P R/L	R AFQD L AB4M X800 X400	Nein / No	0,1	E12.A1 E12.A2	
12°	1,0	E12.1210.11 P R/L	R ANDX L AMEB X800 X400	Ja / Yes	0,1	E12.A1 E12.A2	
▼ w = 1,3 mm							
6°-7°	1,3	E12.0613.11 P R/L	R ABPV L AEZZ X800 X400	Ja / Yes	0,1	E12.A1 E12.A2	
▼ w = 1,6 mm							
6°-7°	1,6	E12.0516.00 P R/L	R ACV8 L AF73 X800 X400	Nein / No	0,1	E12.A1 E12.A2	
6°-7°	1,6	E12.0516.11 P R/L	R AMGM L ACKA X800 X400	Ja / Yes	0,1	E12.A1 E12.A2	
6°-7°	1,6	E12.0516.68 PS R/L	R AWEK L AWEN X800 X400	Nein / No	0,1	E68.A1	
6°-7°	1,6	E12.0516.68 PT R/L	R AWEQ L AWEP X800 X400	Ja / Yes	0,1	E68.A1	
▼ w = 2,0 mm							
5°-6°	2,0	E12.0520.00 P R/L	R AC2J L ACEX X800 X400	Nein / No	0,1	E12.A1 E12.A2	
5°-6°	2,0	E12.0520.11 P R/L	R ANDM L AJEN X800 X400	Ja / Yes	0,1	E12.A1 E12.A2	
15°	2,0	E12.1520.11 P R/L	R AFED L APJT X800 X400	Ja / Yes	0,1	E12.A1 E12.A2	
▼ w = 2,1 mm							
5°-6°	2,1	E12.0521.11 P R/L	R AN1B L AHHT X800 X400	Ja / Yes	0,1	E12.A2 E12.B2	

Bestellbeispiel // Order example: E12.1210.11 P R X800 (R = Rechte Ausführung // Right hand version, X800 = Schneidstoff // Grade)

E12...00 P R / E12...PS R: Für die Bearbeitung eines breiten Metarialspektrums // For a wide variety of workpiecematerials.

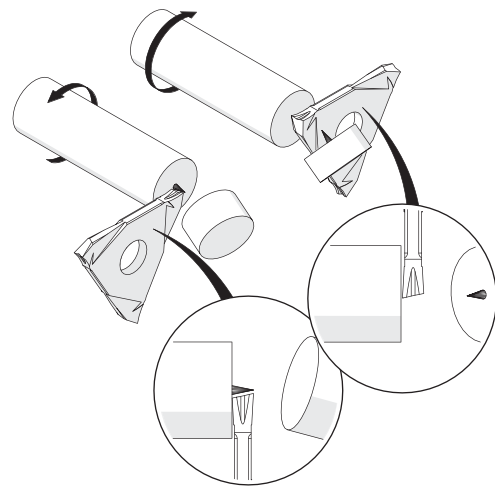
E12...11 P R / E12...PT R: Für die Bearbeitung eines breiten Metarialspektrums sowie besonders für langspanendes Material und hohe Stechtiefen.
 For a wide variety of workpiecematerials as well as especially for long-chipping materials and high cutting depths.