

Allgemeines Nutfräsen

Nutfräsen gerader Nutformen.
 Geeignet ab Bohrungsdurchmesser 16,0 mm.

General Groove Milling

General groove milling.
 For use in bores as of minimum bore diameter 16,0 mm.

Schnittwerte (Start) // Cutting parameters (start)		
fzm	hmax	Vc
0,02 mm	0,03 mm	Seite/Page 638

Passende Klemmhalter auf Seite // Suitable toolholders on page
508, 509, 510, 511, 512

Vergleichbare Werkzeuge auf Seite // Similar tools on page
461

Bitte Hinweise im Anhang beachten // Please read add. notes
ALL (Seite/Page 645), H01 (Seite/Page 646)

SP Legende
HM Legend

650

Scan QR-Code Oder besuchen Sie // Or Visit
www.simtek.info/cp/368

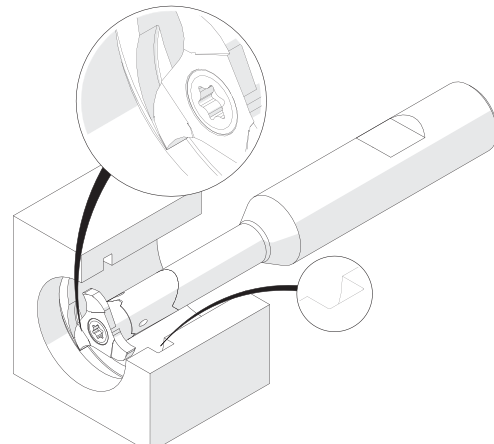
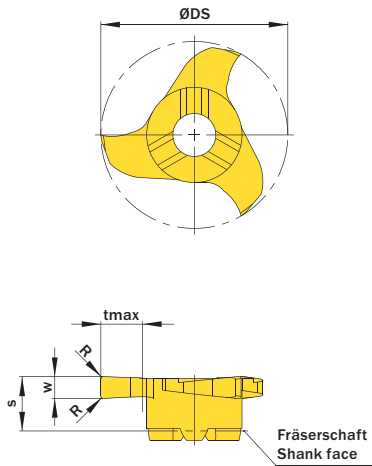

Illustration zeigt beispielhafte Anwendungsmöglichkeit mit ähnlichem Werkzeug.
 Image shows exemplary application possibility with similar tool.

Abbildung zeigt / Drawing shows: S16.0200.02 G

w ^{+0,02}	Nutnenbreite Nominal width of groove	R	ØDmin (Min. Bohrung) ØDmin (min. bore)	Artikelnummer Part number	Webcode www.simtek.com/webcode	Unsere erste Wahl Our first choice	tmax	S	ØDS	Anzahl Schneiden Number of cutting edges	Connectcode www.simtek.com/code	
mm	mm	mm	mm			P M K N S	mm	mm	mm			
1,168	-	-	16,0	S16.0117.00 G	ABPS	X800 GT42	3,5	4,5	15,7	3	SD08.0	inch
1,422	-	-	16,0	S16.0142.00 G	AFV8	X800 GT42	3,5	4,5	15,7	3	SD08.0	inch
1,5	-	0,2	16,0	S16.0150.02 G	AMBC	X800 GT42	3,5	4,5	15,7	3	SD08.0	
1,575	-	0,2	16,0	S16.0157.02 G	ACMX	X800 GT42	3,5	4,5	15,7	3	SD08.0	inch
2,0	-	0,2	16,0	S16.0200.02 G	ABYC	X800 GT42	3,5	4,5	15,7	3	SD08.0	
2,388	-	0,2	16,0	S16.0239.02 G	AFN8	X800 GT42	3,5	4,5	15,7	3	SD08.0	inch
2,5	-	0,2	16,0	S16.0250.02 G	AF11	X800 GT42	3,5	4,5	15,7	3	SD08.0	
3,175	-	0,2	16,0	S16.0318.02 G	A4SB	X800 GT42	3,5	4,5	15,7	3	SD08.0	new inch

Bestellbeispiel // Order example: **S16.0200.02 G X800** (X800 = Schneidstoff // Grade)



S16. **w, 1/100 mm, 4 Stellen/Digits** . **R, 1/100 mm, 3 Stellen/Digits** **Toleranz // Tolerance**
 Beispielartikelnummer // Example Part number: **S16.0179.030 XG**