

# Fräserschaft, für Spannzangenfutter (DIN 6499)

Für Spannzangenfutter nach DIN6499-A.

# Milling cutter shank, for collet chucks (DIN6499)

For collet chucks according to DIN6499-A.

Anzugsmoment (Schraube) // Tightening torque (screw)

**7,0 Nm**

Vergleichbare Werkzeuge auf Seite // Similar tools on page  
**472**

Bitte Hinweise im Anhang beachten // Please read add. notes  
**ALL (Seite/Page 645)**



**TW**  
**ST**

Legende  
Legend

**650**



Scan  
QR-Code

Oder besuchen Sie // Or Visit  
**www.simtek.info/cp/456**

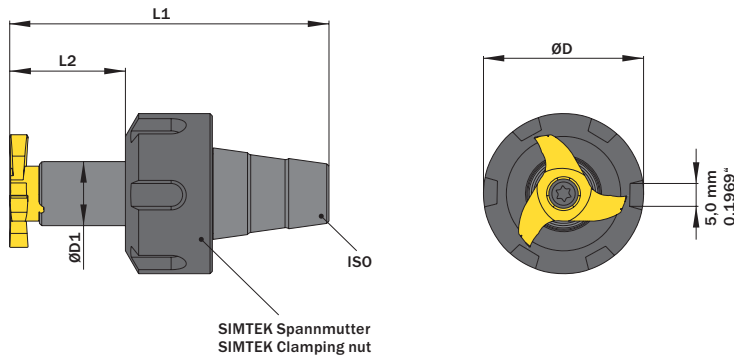

Fräserschaft ist nur mit passender Spannmutter verfügbar.  
Spannmutter ist auch einzeln als Ersatzteil verfügbar.  
Milling cutter shank is only available together with clamping nut.  
Clamping nut is available as a spare part.

Für Spannzange For collet chuck	ØD1 mm	L2 mm	Artikelnummer Part number	Webcode www.simtek.com/webcode	Spannmutter Clamping nut	Gewinde Spannmutter Thread clamping nut	ØD mm	L1 mm	Schraube Screw	Schraubenschlüssel Screw driver	Connectcode www.simtek.com/code
<b>▼ Für Spannzange // For collet chuck = ER16</b>											
ER16	12,0	30,0	<b>V22.ER16.12.30</b>	AD5W	VER16.18.32	M22x1,5	32,0	60,0	VM5x12 T20T	T20T	VD12.0
ER16	12,0	30,0	<b>V22.ER16.12.30.B</b>	AVMX	VER16.18.22	M19x1,0	22,0	60,0	VM5x12 T20T	T20T	VD12.0
ER16	12,0	30,0	<b>V22.ER16.12.30.C</b>	AVMY	VER16.18.25	M19x1,0	25,0	60,0	VM5x12 T20T	T20T	VD12.0
<b>▼ Für Spannzange // For collet chuck = ER20</b>											
ER20	12,0	30,0	<b>V22.ER20.12.30</b>	APJ7	VER20.19.35	M25x1,5	35,0	65,65	VM5x12 T20T	T20T	VD12.0
ER20	12,0	30,0	<b>V22.ER20.12.30.B</b>	AVM1	VER20.19.28	M24x1,0	28,0	65,65	VM5x12 T20T	T20T	VD12.0
ER20	14,0	35,0	<b>V28.ER20.14.35</b>	ABJC	VER20.19.35	M25x1,5	35,0	69,5	VM5x12 T20T	T20T	VD14.0
ER20	14,0	35,0	<b>V28.ER20.14.35.B</b>	AVM2	VER20.19.28	M24x1,0	28,0	69,5	VM5x12 T20T	T20T	VD14.0
<b>▼ Für Spannzange // For collet chuck = ER25</b>											
ER25	12,0	30,0	<b>V22.ER25.12.30</b>	AESQ	VER25.20.42	M32x1,5	42,0	68,0	VM5x12 T20T	T20T	VD12.0
ER25	12,0	30,0	<b>V22.ER25.12.30.B</b>	AVM4	VER25.20.35	M30x1,0	35,0	68,0	VM5x12 T20T	T20T	VD12.0
ER25	14,0	19,0	<b>V22.ER25.14.19</b>	AMP6	VER25.20.42	M32x1,5	42,0	63,0	VM5x12 T20T	T20T	VD14.0
ER25	14,0	19,0	<b>V22.ER25.14.19.B</b>	AVM5	VER25.20.35	M30x1,0	35,0	63,0	VM5x12 T20T	T20T	VD14.0
ER25	14,0	35,0	<b>V28.ER25.14.35</b>	APAS	VER25.20.42	M32x1,5	42,0	73,0	VM5x12 T20T	T20T	VD14.0
ER25	14,0	35,0	<b>V28.ER25.14.35.B</b>	AVM6	VER25.20.35	M30x1,0	35,0	73,0	VM5x12 T20T	T20T	VD14.0
<b>▼ Für Spannzange // For collet chuck = ER32</b>											
ER32	12,0	30,0	<b>V22.ER32.12.30</b>	AFVA	VER32.23.50	M40x1,5	50,0	74,0	VM5x12 T20T	T20T	VD12.0
ER32	14,0	19,0	<b>V22.ER32.14.19</b>	AKXJ	VER32.23.50	M40x1,5	50,0	63,0	VM5x12 T20T	T20T	VD14.0
ER32	14,0	35,0	<b>V28.ER32.14.35</b>	AC0B	VER32.23.50	M40x1,5	50,0	79,0	VM5x12 T20T	T20T	VD14.0

Bestellbeispiel // Order example: **V28.ER25.14.35**

simmill AX  
simmill PMX  
simmill PX  
simmill SX  
simmill UX  
simmill VX  
simmill H2  
simmill K2  
simmill MX  
simmill OS  
Index