

Einstecken und Profildrehen

CNC-Feindrehen.

Grooving and Profiling

CNC profiling.

Schnittwerte (Start) // Cutting parameters (start)	
f	Vc
0,04 mm/U	Seite/Page 429

Passende Klemmhalter auf Seite // Suitable toolholders on page
361, 362, 363, 364, 365, 367

SP
Legende

HM
Legende

Scan QR-Code

389

Oder besuchen Sie // Or Visit
www.simtek.info/cp/865



Abbildung zeigt / Drawing shows: E12.0300.06 N

w +0,03 mm	R mm	Artikelnummer Part number	Webcode www.simtek.com/webcode	Unsere erste Wahl Our first choice P K M N S	Connectcode www.simtek.com/code
----------------------	----------------	------------------------------	---	---	---

◀ Fortgesetzte Tabelle Continued Table **Verwandte Werkzeuge finden Sie auch auf der vorhergehenden Seite!**
 Related items can be found on the previous page as well!

▼ w = 3,0 mm						
	3,0	0,05	E12.0300.00 N	AGUD	X800 X400	E12.B2
	3,0	0,2	E12.0300.02 N	ABEQ	X800 X400	E12.B2
	3,0	0,4	E12.0300.04 N	AA6U	X800 X400	E12.B2
	3,0	0,6	E12.0300.06 N	AMZM	X800 X400	E12.B2
	3,0	0,8	E12.0300.08 N	AJV3	X800 X400	E12.B2
▼ w = 4,0 mm						
	4,0	0,05	E12.0400.00 N	AP2K	X800 X400	E12.C3
	4,0	0,2	E12.0400.02 N	ADXN	X800 X400	E12.C3
	4,0	0,4	E12.0400.04 N	AFJK	X800 X400	E12.C3
	4,0	0,8	E12.0400.08 N	AJP0	X800 X400	E12.C3
	4,0	1,2	E12.0400.12 N	AKU8	X800 X400	E12.C3

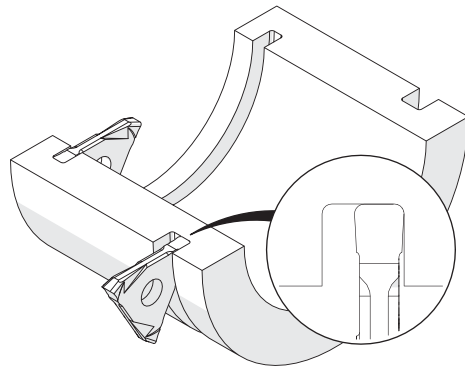
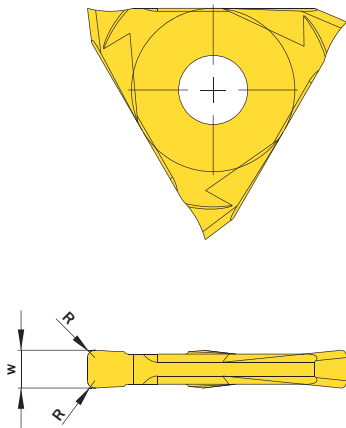
Bestellbeispiel // Order example: **E12.0300.02 N X800** (X800 = Schneidstoff // Grade)



E12. w, 1/100 mm, 4 Stellen/Digits . R, 1/100 mm, 3 Stellen/Digits Toleranz // Tolerance
 Beispielpartikelnummer // Example Part number: **E12.0156.015 XN**

simturn AX
simturn DX
simturn PX
simturn H2
simturn K2
simturn C4
simturn GX
simturn E3
simturn E12
simturn FX
simturn Decolletage
simturn OA
Index