

Nutenstechen

Für allgemeines Nutenstechen und für Sicherungsringnuten.
Geeignet ab Bohrungsdurchmesser 8,0 mm.

Grooving

For general grooving as well as for circlip ring grooving.
For use in bores as of minimum bore diameter 8,0 mm.

| Schnittwerte (Start) // Cutting parameters (start) | |
|--|-----------------------------|
| f 0,02 mm/U | Vc Seite/Page 429 |

| |
|---|
| Passende Klemmhalter auf Seite // Suitable toolholders on page 154, 163 |
|---|

| |
|--|
| Vergleichbare Werkzeuge auf Seite // Similar tools on page 175 |
|--|

SP

HM

R

Legende
Legend **213**

Scan
QR-Code

Oder besuchen Sie // Or Visit
www.simtek.info/cp/829



Abbildung zeigt / Drawing shows: D08.0110.00 G R

| w ^{+0,03} | Nutnenbreite Nominal width of groove | ØDmin (Min. Bohrung) ØDmin (min. bore) | Artikelnummer Part number | Webcode www.simtek.com/webcode | Unsere erste Wahl Our first choice | a | Ød | f | R | S | tmax | Connectcode www.simtek.com/code |
|--------------------|---|---|------------------------------|-----------------------------------|---------------------------------------|----|----|----|----|----|------|------------------------------------|
| mm | mm | mm | | | P K M N S | mm | mm | mm | mm | mm | mm | |

◀ Fortgesetzte Tabelle Continued Table Verwandte Werkzeuge finden Sie auch auf der vorhergehenden Seite!
Related items can be found on the previous page as well!

| | | | | | | | | | | | | |
|-------|-----|-----|-------------------------|---------------|-----------|-----|-----|-----|---|-----|-----|-----|
| 0,73 | 0,7 | 8,0 | D08.0070.00 ZR/L | R AB9U L ADBZ | X800 X400 | 7,8 | 6,0 | 4,8 | - | 3,3 | 1,0 | D08 |
| 0,787 | - | 8,0 | D08.0078.00 GR/L | R ANEN L AH0A | X800 X400 | 7,8 | 6,0 | 4,8 | - | 3,3 | 1,0 | D08 |
| 0,83 | 0,8 | 8,0 | D08.0080.00 ZR/L | R AKJ6 L AMGG | X800 X400 | 7,8 | 6,0 | 4,8 | - | 3,3 | 1,0 | D08 |
| 0,93 | 0,9 | 8,0 | D08.0090.00 ZR/L | R AN56 L AMYN | X800 X400 | 7,8 | 6,0 | 4,8 | - | 3,3 | 1,0 | D08 |
| 1,0 | - | 8,0 | D08.0100.00 GR/L | R AKUA L AGCE | X800 X400 | 7,8 | 6,0 | 4,8 | - | 3,3 | 1,0 | D08 |
| 1,2 | 1,1 | 8,0 | D08.0110.00 GR/L | R ABPM L ANT9 | X800 X400 | 7,8 | 6,0 | 4,8 | - | 3,3 | 1,0 | D08 |
| 1,4 | 1,3 | 8,0 | D08.0130.00 GR/L | R AMN4 L AG33 | X800 X400 | 7,8 | 6,0 | 4,8 | - | 3,3 | 1,0 | D08 |
| 1,5 | - | 8,0 | D08.0150.00 GR/L | R AK83 L AFKC | X800 X400 | 7,8 | 6,0 | 4,8 | - | 3,3 | 1,0 | D08 |
| 1,575 | - | 8,0 | D08.0157.00 GR/L | R AKYG L AHA1 | X800 X400 | 7,8 | 6,0 | 4,8 | - | 3,3 | 1,0 | D08 |
| 1,7 | 1,6 | 8,0 | D08.0160.00 GR/L | R ACV2 L AGGD | X800 X400 | 7,8 | 6,0 | 4,8 | - | 3,3 | 1,0 | D08 |
| 1,981 | - | 8,0 | D08.0198.00 GR/L | R AE0H L AK8B | X800 X400 | 7,8 | 6,0 | 4,8 | - | 3,3 | 1,0 | D08 |
| 2,0 | - | 8,0 | D08.0200.00 GR/L | R AJB6 L ANSM | X800 X400 | 7,8 | 6,0 | 4,8 | - | 3,3 | 1,0 | D08 |

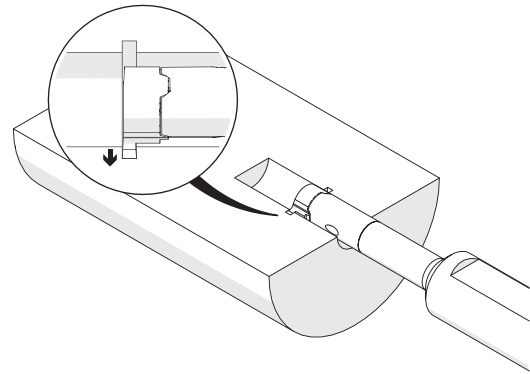
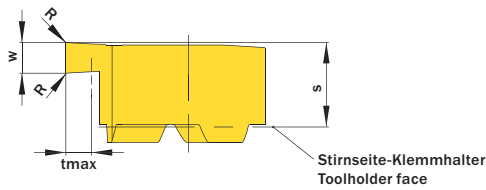
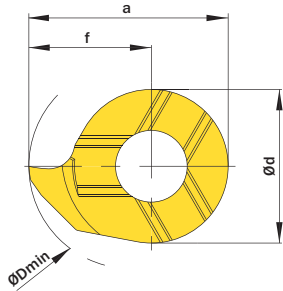
Verwandte Werkzeuge finden Sie auch auf der folgenden Seite!
Related items can be found on the following page as well!

▶ Fortgesetzte Tabelle Continued Table

|| Bestellbeispiel // Order example: **D08.0150.00 GR X800** (R = Rechte Ausführung // Right hand version, X800 = Schneidstoff // Grade)



D08. w, 1/100 mm, 4 Stellen/Digits . R, 1/100 mm, 3 Stellen/Digits Toleranz // Tolerance R/L
Beispielartikelnummer // Example Part number: **D08.0156.015 XN R** oder//or **D08.0156.015 XN L**