

Gewindedrehen, ACME / STUB-ACME, Teilprofil

Teilprofil für ACME- und STUB-ACME-Gewinde.

Threading, ACME / STUB-ACME, Partial Profile

Partial profile for internal ACME- and STUB-ACME thread.

Schnittwerte (Start) // Cutting parameters (start)
Anzahl Durchgänge // Number of passes 12 - 18
Empf. Zustellungsart // Recom. infeed method Flankenzustellung // Flank infeed (Seite/Page 433)
Vc Seite/Page 429

Passende Klemmhalter auf Seite // Suitable toolholders on page
156, 157, 161, 163, 164

SP
HM

Legende
Legend

213

Scan QR-Code Oder besuchen Sie // Or Visit www.simtek.info/cp/820

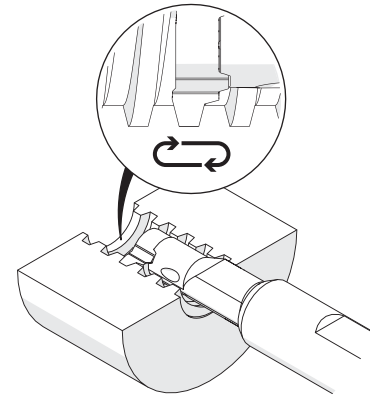
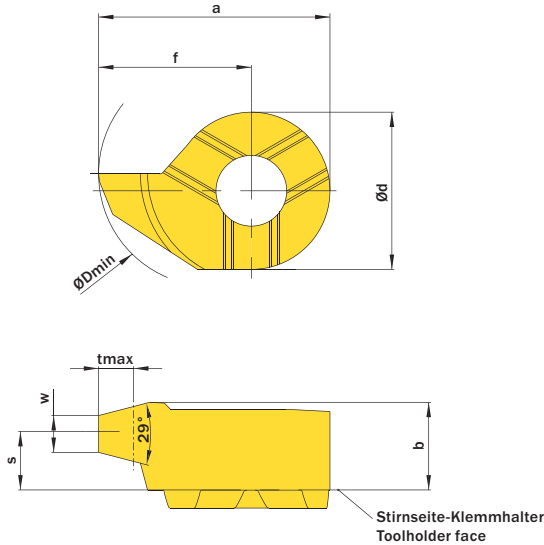

Gang/Zoll Threads/Inch	ØDmin (Min. Bohrung) ØDmin (min. bore)	Gewindetyp	Artikelnummer Part number	Webcode www.simtek.com/webcode	Unsere erste Wahl Our first choice					a	b	Ød	f	Steigung (von) Pitch (as of)	S	w	tmax	Connectcode www.simtek.com/ccode
					P	K	M	N	S									
▼ Gang/Zoll // Threads/Inch = 10																		
10	10,0	STUB-ACME	D10.SA10.01.10 MR/L	R AGDD L AFWG	X800	X400	9,3	3,9	7,0	5,8	2,54	2,9	0,94	1,19	D10			
▼ Gang/Zoll // Threads/Inch = 12																		
12	10,0	STUB-ACME	D10.SA12.01.10 MR/L	R AS1G L ATV7	X800	X400	9,3	3,9	7,0	5,8	2,117	2,95	0,82	0,92	D10			
▼ Gang/Zoll // Threads/Inch = 5																		
5	11,0	ACME	D10.AC05.01.11 MR	A3TD	X800	X400	10,3	3,7	7,0	6,8	5,08	1,9	1,75	2,79	D10			
5	10,0	STUB-ACME	D10.SA05.01.10 MR/L	R AFAM L AE4B	X800	X400	9,3	3,7	7,0	5,8	5,08	1,95	2,01	2,04	D10			
▼ Gang/Zoll // Threads/Inch = 6																		
6	11,0	ACME	D10.AC06.01.11 MR/L	R AEAB L AJ18	X800	X400	10,3	3,9	7,0	6,8	4,233	2,3	1,43	2,63	D10			
6	10,0	STUB-ACME	D10.SA06.01.10 MR/L	R AK49 L AGC9	X800	X400	9,3	3,7	7,0	5,8	4,233	2,35	1,65	1,76	D10			
6	11,0	ACME	D11.AC06.01 MR/L	R AKTH L ATV6	X800	X400	10,7	3,95	8,0	6,7	4,233	2,5	1,43	2,39	D11			
▼ Gang/Zoll // Threads/Inch = 8																		
8	11,0	ACME	D10.AC08.01.11 MR/L	R AJCF L AHZU	X800	X400	10,3	3,9	7,0	6,8	3,175	2,65	1,04	2,1	D10			
8	10,0	STUB-ACME	D10.SA08.01.10 MR/L	R AB7E L AF6Z	X800	X400	9,3	3,72	7,0	5,8	3,175	2,3	1,21	1,41	D10			

Bestellbeispiel // Order example: **D10.AC06.01.11 MR X800** (R = Rechte Ausführung // Right hand version, X800 = Schneidstoff // Grade)

simturn AX
simturn DX
simturn PX
simturn H2
simturn K2
simturn C4
simturn GX
simturn E3
simturn E12
simturn FX
simturn Decolletage
simturn OA
Index