

# Gewindedrehen, Metr. ISO, Innen, Teilprofil

Mehrbereichswerkzeuge für unterschiedliche Steigungen.

# Threading, Metr. ISO, Internal, Partial Profile

Multi-purpose tools, usable for different pitches.

Schnittwerte (Start) // Cutting parameters (start)

f	Vc
0,02 mm/U	Seite/Page 429

Passende Klemmhalter auf Seite // Suitable toolholders on page

31, 32, 34, 40, 41, 43, 50, 51, 53, 55, 56, 57, 60, 62, 63, 66, 67, 68, 69

Empf. Zustellungsart // Recom. infeed method  
**Flankenzustellung // Flank infeed (Seite/Page 433)**

Bitte Hinweise im Anhang beachten // Please read add. notes  
**T01 (Seite/Page 137)**



**SP** **HM** **R** Legende Legend **139**

Scan QR-Code Oder besuchen Sie // Or Visit [www.simtek.info/cp/767](http://www.simtek.info/cp/767)



Abbildung zeigt / Drawing shows: A04.M045.01.06.17 M R



Mehr Informationen zur Kühlmittelzufuhr finden Sie auf Seite 22  
Additional information about through coolant supply on page 22

ØD	Steigung (von Pitch (as of)	L2	ØDmin (Min. Bohrung) ØDmin (min. bore)	Kühlmittelzufuhr Through coolant supply	Artikelnummer Part number	Webcode <a href="http://www.simtek.com/webcode">www.simtek.com/webcode</a>	Unsere erste Wahl Our first choice	Regelgewinde Standard pitch thread	a	d	LH	S	t	w	Connectcode <a href="http://www.simtek.com/code">www.simtek.com/code</a>	
mm	mm	mm	mm				P K M N S		mm	mm	mm	mm	mm	mm		
▼ Regelgewinde // Standard pitch thread = M1																
4,0	0,25	2,5	0,73	+	A04.M025.01.02.07 MR/L	R ABK0	L AD4Z	X800 X400	M1	0,67	0,39	13,0	0,14	0,14	0,03	R A04C.R L A04C.L
▼ Regelgewinde // Standard pitch thread = M1,6																
4,0	0,35	4,1	1,22	+	A04.M035.01.04.12 MR/L	R AKSA	L AE2B	X800 X400	M1,6	1,1	0,71	13,0	0,18	0,19	0,04	R A04C.R L A04C.L
▼ Regelgewinde // Standard pitch thread = M2																
4,0	0,4	5,1	1,57	+	A04.M040.01.05.15 MR/L	R AB5T	L AG6C	X800 X400	M2	1,4	0,98	13,0	0,2	0,22	0,05	R A04C.R L A04C.L
▼ Regelgewinde // Standard pitch thread = M2,2																
4,0	0,45	6,1	1,71	+	A04.M045.01.06.17 MR/L	R AH5G	L ACVW	X800 X400	M2,2	1,45	1,01	13,0	0,22	0,24	0,06	R A04C.R L A04C.L
▼ Regelgewinde // Standard pitch thread = M3																
4,0	0,5	7,6	2,46	+	A04.M050.01.07.24 MR/L	R ADAU	L ABCW	X800 X400	M3	2,2	1,73	13,0	0,24	0,27	0,06	R A04C.R L A04C.L
▼ Regelgewinde // Standard pitch thread = M4																
4,0	0,7	10,2	3,24	+	A04.M070.01.10.32 MR/L	R ABVG	L AAKY	X800 X400	M4	2,95	2,37	13,0	0,32	0,38	0,09	R A04C.R L A04C.L
4,0	0,7	15,2	3,24	+	A04.M070.01.15.32 MR/L	R A05G	L A05H	X800 X400	M4	2,95	2,37	18,0	0,32	0,38	0,09	R A04C.R L A04C.L

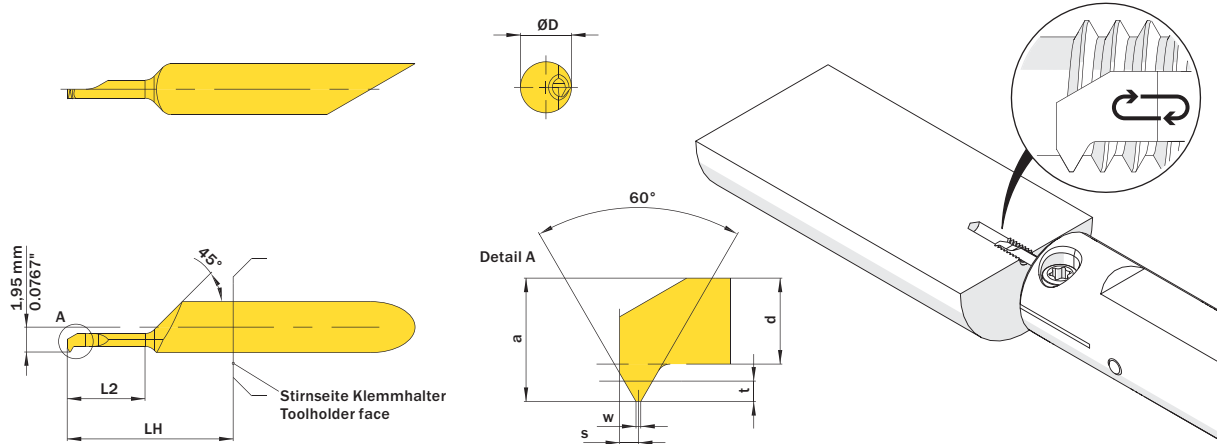
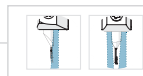
Bestellbeispiel // Order example: **A04.M035.01.04.12 MR X800** (R = Rechte Ausführung // Right hand version, X800 = Schneidstoff // Grade)

Bitte beachten Sie die zusätzlichen Hinweise im Infobereich rechts oben.

Please read the additional notes mentioned in the information area on the top right corner of this page.