

# Axialeinstiche in Bohrungen

Geeignet ab Bohrungsdurchmesser 14,0 mm.

## Face Grooving in bores

For use in bores as of minimum bore diameter 14,0 mm.

Schnittwerte (Start) // Cutting parameters (start)

f	Vc
0,02 mm/U	Seite/Page 429

Passende Klemmhalter auf Seite // Suitable toolholders on page  
165, 166, 167

**SP HM**

Legende Legend **213**

Scan QR-Code Oder besuchen Sie // Or Visit [www.simtek.info/cp/818](http://www.simtek.info/cp/818)

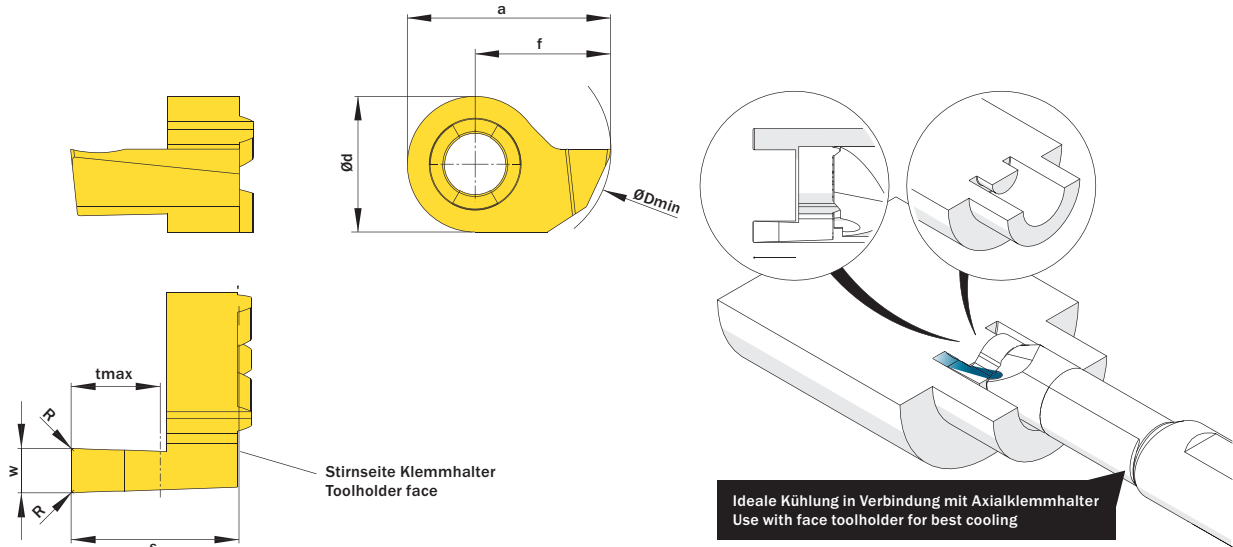

Abbildung zeigt / Drawing shows: D14.1430.62 A R

ØDmin (Min. Bohrung) ØDmin (min. bore)	w <sup>+0,03</sup>	R	tmax	Artikelnummer Part number	Webcode www.simtek.com/webcode	Unsere erste Wahl Our first choice	a	Ød	f	S	Connectcode www.simtek.com/code
mm	mm	mm	mm			P K M N S	mm	mm	mm	mm	
<b>▼ tmax = 1,5 mm</b>											
14,0	1,0	-	1,5	<b>D14.1410.00 AR/L</b>	R AB03 L AJC4	X800 X400	13,5	9,0	9,0	8,3	R D14.A.R L D14.A.L
14,0	1,168	-	1,5	<b>D14.1411.00 AR/L</b>	R AA1G L AGEN	X800 X400	13,5	9,0	9,0	8,3	R D14.A.R L D14.A.L <span style="float: right;">inch</span>
<b>▼ tmax = 2,5 mm</b>											
14,0	1,5	0,2	2,5	<b>D14.1415.02 AR/L</b>	R AET8 L ABZX	X800 X400	13,5	9,0	9,0	8,3	R D14.A.R L D14.A.L
14,0	1,6	0,2	2,5	<b>D14.1416.02 AR/L</b>	R AC9S L AGVC	X800 X400	13,5	9,0	9,0	8,3	R D14.A.R L D14.A.L
14,0	1,575	0,2	2,5	<b>D14.1416.020 AR</b>	A4VN	X800 X400	13,5	9,0	9,0	8,3	<b>D14.A.R</b> <span style="float: right;">new</span>
<b>▼ tmax = 3,0 mm</b>											
14,0	2,0	0,2	3,0	<b>D14.1420.02 AR/L</b>	R AKZS L AG57	X800 X400	13,5	9,0	9,0	8,3	R D14.A.R L D14.A.L <span style="float: right;">inch</span>
14,0	2,388	0,2	3,0	<b>D14.1424.02 AR/L</b>	R AF82 L AHNH	X800 X400	13,5	9,0	9,0	8,3	R D14.A.R L D14.A.L <span style="float: right;">inch</span>
14,0	2,5	0,2	3,0	<b>D14.1425.02 AR/L</b>	R AMKF L AJN5	X800 X400	13,5	9,0	9,0	8,3	R D14.A.R L D14.A.L
14,0	3,0	0,2	3,0	<b>D14.1430.02 AR/L</b>	R ABPP L AMDG	X800 X400	13,5	9,0	9,0	8,3	R D14.A.R L D14.A.L
14,0	3,175	0,2	3,0	<b>D14.1432.02 AR/L</b>	R AHGE L AMA5	X800 X400	13,5	9,0	9,0	8,3	R D14.A.R L D14.A.L <span style="float: right;">inch</span>
<b>▼ tmax = 5,0 mm</b>											
14,0	2,0	0,2	5,0	<b>D14.1420.52 AR/L</b>	R AGV5 L AATA	X800 X400	13,5	9,0	9,0	10,3	R D14.A.R L D14.A.L
14,0	2,388	0,2	5,0	<b>D14.1424.52 AR/L</b>	R AF3H L AMMD	X800 X400	13,5	9,0	9,0	10,3	R D14.A.R L D14.A.L <span style="float: right;">inch</span>
14,0	2,5	0,2	5,0	<b>D14.1425.52 AR/L</b>	R ACQN L AGFZ	X800 X400	13,5	9,0	9,0	10,3	R D14.A.R L D14.A.L
14,0	3,0	0,2	5,0	<b>D14.1430.52 AR/L</b>	R AKV7 L AJKK	X800 X400	13,5	9,0	9,0	10,3	R D14.A.R L D14.A.L
14,0	3,175	0,2	5,0	<b>D14.1432.52 AR/L</b>	R AGHH L ANZK	X800 X400	13,5	9,0	9,0	10,3	R D14.A.R L D14.A.L <span style="float: right;">inch</span>
<b>▼ tmax = 6,0 mm</b>											
14,0	3,0	0,2	6,0	<b>D14.1430.62 AR</b>	AGU2	X800 X400	13,5	9,0	9,0	11,3	<b>D14.A.R</b>
<b>▼ tmax = 10,0 mm</b>											
18,0	3,0	0,2	10,0	<b>D18.1830.10.02 AR/L</b>	R AGNP L AVST	X800 X400	16,5	11,0	11,0	15,8	R D18.18.A.R L D18.18.A.L
18,0	4,0	0,2	10,0	<b>D18.1840.10.02 AR/L</b>	R AVJW L AVSU	X800 X400	17,0	11,0	11,5	15,8	R D18.18.A.R L D18.18.A.L

Bestellbeispiel // Order example: **D14.1430.62 AR X800** (R = Rechte Ausführung // Right hand version, X800 = Schneidstoff // Grade)