

Allgemeines Nutfräsen

Nutfräsen gerader Nutformen.
 Geeignet ab Bohrungsdurchmesser 25,0 mm.

General Groove Milling

General groove milling.
 For use in bores as of minimum bore diameter 25,0 mm.

Schnittwerte (Start) // Cutting parameters (start)		
fzm	hmax	Vc
0,04 mm	0,05 mm	Seite/Page 638

Passende Klemmhalter auf Seite // Suitable toolholders on page
556, 557, 558, 559, 560, 561, 563

Vergleichbare Werkzeuge auf Seite // Similar tools on page
461

Bitte Hinweise im Anhang beachten // Please read add. notes
ALL (Seite/Page 645), H01 (Seite/Page 646)

SP

Legende

HM

Legend

650

Scan QR-Code

Oder besuchen Sie // Or Visit www.simtek.info/cp/375

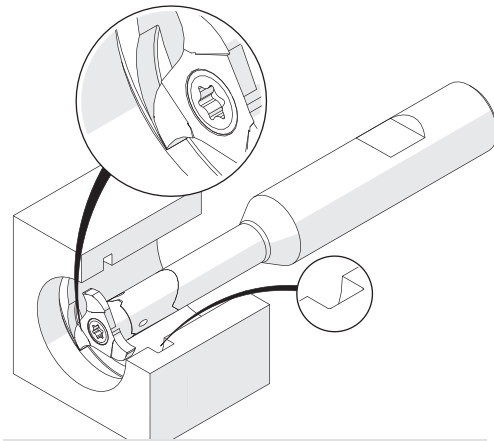
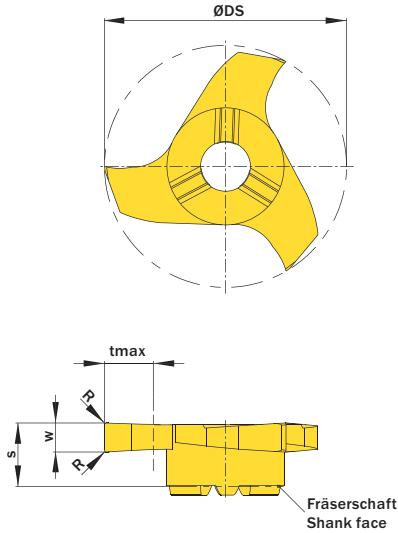

Illustration zeigt beispielhafte Anwendungsmöglichkeit mit ähnlichem Werkzeug.
 Image shows exemplary application possibility with similar tool.

Abbildung zeigt / Drawing shows: V25.0300.02 G

w ^{+0,02}	R	ØDmin (Min. Bohrung) ØDmin (min. bore)	Artikelnummer Part number	Webcode www.simtek.com/webcode	Unsere erste Wahl Our first choice	tmax	S	ØDS	Anzahl Schneiden Number of cutting edges	Connectcode www.simtek.com/code
mm	mm	mm			P M K N S	mm	mm	mm		
2,0	0,2	25,0	V25.0200.02 G	AHS7	X800 GT42	5,0	6,6	24,8	3	VD14.0 VD14.3
2,388	0,2	25,0	V25.0239.02 G	APTW	X800 GT42	5,0	6,6	24,8	3	VD14.0 VD14.3
2,5	0,2	25,0	V25.0250.02 G	ACG1	X800 GT42	5,0	6,6	24,8	3	VD14.0 VD14.3
3,0	0,2	25,0	V25.0300.02 G	AFPB	X800 GT42	5,0	6,6	24,8	3	VD14.0 VD14.3
3,175	0,2	25,0	V25.0318.02 G	AAZ4	X800 GT42	5,0	6,6	24,8	3	VD14.0 VD14.3
3,5	0,2	25,0	V25.0350.02 G	AKG8	X800 GT42	5,0	6,6	24,8	3	VD14.0 VD14.3
4,0	0,2	25,0	V25.0400.02 G	AA9X	X800 GT42	5,0	6,6	24,8	3	VD14.0 VD14.3
4,75	0,2	25,0	V25.0475.02 G	AMMV	X800 GT42	5,0	6,6	24,8	3	VD14.0 VD14.3
5,0	0,2	25,0	V25.0500.02 G	AZCF	X800 GT42	5,0	6,6	24,8	3	VD14.0 VD14.3

Bestellbeispiel // Order example: **V25.0200.02 G X800** (X800 = Schneidstoff // Grade)



V25. w, 1/100 mm, 4 Stellen/Digits . R, 1/100 mm, 3 Stellen/Digits Toleranz // Tolerance
 Beispielartikelnummer // Example Part number: **V25.0179.030 XG**