

Ausdrehen und Fasen

Geeignet ab Bohrungsdurchmesser 7,0 mm.

Boring and Chamfering

For use in bores as of minimum bore diameter 7,0 mm.

Schnittwerte (Start) // Cutting parameters (start)

f **0,02 mm/U** Vc **Seite/Page 429**

Passende Klemmhalter auf Seite // Suitable toolholders on page

153, 154, 155, 156, 157, 158, 161, 162, 163, 164



SP **HM** **R** **Legende** **213**
Scan **QR-Code** Oder besuchen Sie // Or Visit **www.simtek.info/cp/816**

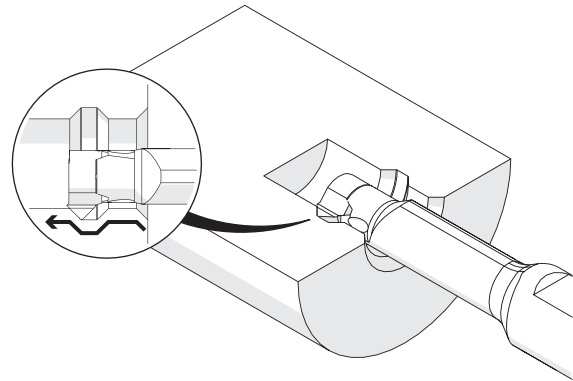
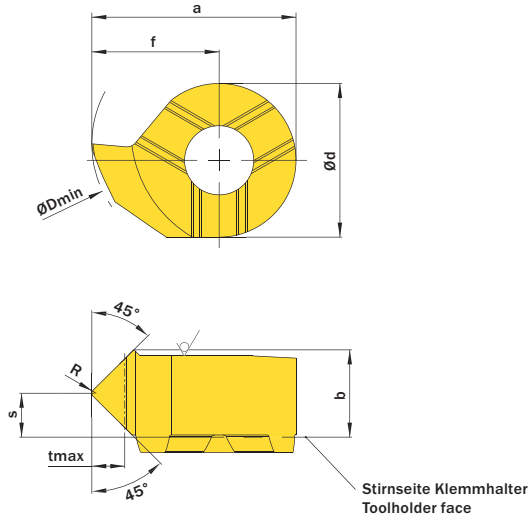

Abbildung zeigt / Drawing shows: D10.4545.02.10 F R

R	Artikelnummer Part number	Webcode www.simtek.com/webcode	Unsere erste Wahl Our first choice	a	b	Ød	ØDmin (Min. Bohrung) ØDmin (min. bore)	f	s	tmax	Connectcode www.simtek.com/code
mm			P K M N S	mm	mm	mm	mm	mm	mm	mm	
▼	ØDmin (Min. Bohrung) // ØDmin (min. bore) = 7,0 mm										
0,2	D07.4545.02.07 FR/L	R AU56	L AXBA X800 X400	6,6	3,7	4,8	7,0	4,2	2,3	0,8	D07
▼	ØDmin (Min. Bohrung) // ØDmin (min. bore) = 8,0 mm										
0,2	D08.4545.02 FR/L	R APXW	L AC28 X800 X400	7,8	3,2	6,0	8,0	4,8	1,6	1,4	D08
▼	ØDmin (Min. Bohrung) // ØDmin (min. bore) = 9,0 mm										
0,2	D09.4545.02.09 FR/L	R AWGH	L AWHY X800 X400	8,6	3,55	6,2	9,0	5,5	1,8	1,3	D09
▼	ØDmin (Min. Bohrung) // ØDmin (min. bore) = 10,0 mm										
0,2	D10.4545.02.10 FR/L	R ACF9	L AAY2 X800 X400	9,3	4,0	7,0	10,0	5,8	2,0	1,5	D10
▼	ØDmin (Min. Bohrung) // ØDmin (min. bore) = 11,0 mm										
0,2	D11.4545.02 FR/L	R AM16	L ACDY X800 X400	10,7	4,3	8,0	11,0	6,7	2,2	1,5	D11
▼	ØDmin (Min. Bohrung) // ØDmin (min. bore) = 14,0 mm										
0,2	D14.4545.02 FR/L	R AKCK	L AM8J X800 X400	13,5	5,35	9,0	14,0	9,0	2,7	1,5	D14

Bestellbeispiel // Order example: **D14.4545.02 FR X800** (R = Rechte Ausführung // Right hand version, X800 = Schneidstoff // Grade)