

Klemmhalter, Innenbearbeitung, Rundschaft

Rundschaft mit innerer Kühlmittelzufuhr für die Größe A06.

Toolholder, Internal Applications, Round Shank

Round shank with through coolant for size A06.

Anzugsmoment (Schraube) // Tightening torque (screw)

7,0 Nm

Bitte Hinweise im Anhang beachten // Please read add. notes

MASTER (Seite/Page 137)



Legende
Legend

139



Scan
QR-Code

Oder besuchen Sie // Or Visit
www.simtek.info/cp/783

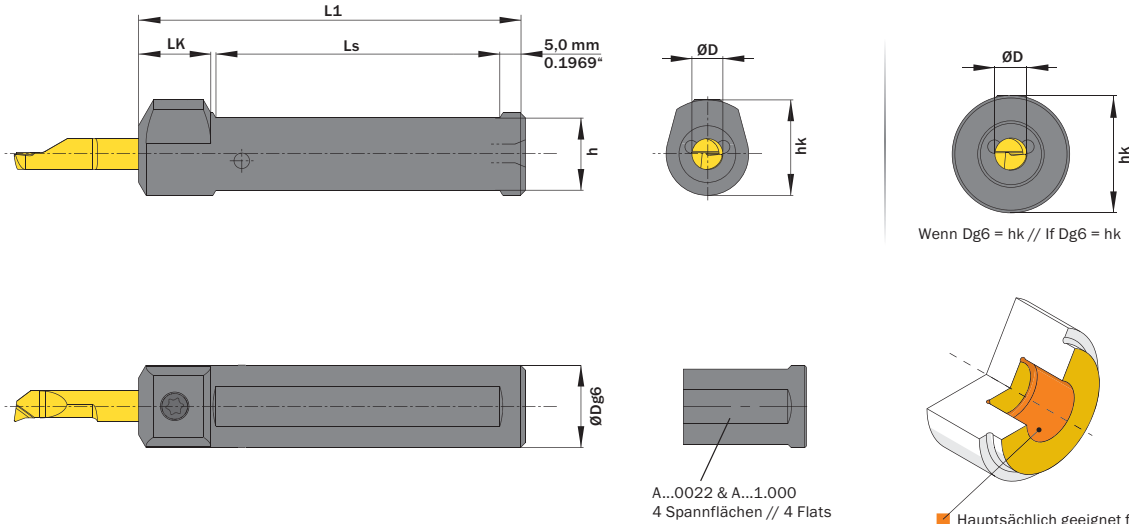

Wenn Dg6 = hk // If Dg6 = hk

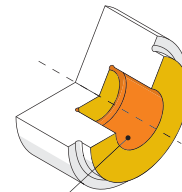

- Hauptsächlich geeignet für diese Flächen
Mainly designed for these surfaces
- Je nach Schneidplatte ebenfalls möglich
Also possible depending on insert type

ØD	ØDg6	Artikelnummer Part number	Webcode www.simtek.com/webcode	h	hk	L1	LK	Ls	Anzahl Spannflächen Number of flats	Schraube Screw	Schraubenschlüssel Screw driver	Connectcode www.simtek.com/code
mm	mm			mm	mm	mm	mm	mm				

Fortgesetzte Tabelle
Continued Table

Verwandte Werkzeuge finden Sie auch auf der vorhergehenden Seite!
Related items can be found on the previous page as well!

6,0	12,0	A06.0012	AE6Z	10,0	16,5	70,0	14,0	50,0	2	A M6x7,5 T15F	T15F	A06.L A06.R
6,0	12,7	A06.0.500	ADG8	10,7	16,85	70,0	14,0	50,0	2	A M6x7,5 T15F	T15F	A06.L A06.R <small>inch</small>
6,0	15,875	A06.0.625	AF4V	13,88	18,44	75,0	14,0	55,0	2	A M6x7,5 T15F	T15F	A06.L A06.R <small>inch</small>
6,0	16,0	A06.0016	ANUJ	14,0	18,5	75,0	14,0	55,0	2	A M6x7,5 T15F	T15F	A06.L A06.R
6,0	19,05	A06.0.750	AE0N	17,05	21,0	110,0	14,0	90,0	2	A M6x7,5 T15F	T15F	A06.L A06.R <small>inch</small>
6,0	20,0	A06.0020	AEV6	18,0	22,0	90,0	14,0	70,0	2	A M6x7,5 T15F	T15F	A06.L A06.R
6,0	22,0	A06.0022	AAW6	20,0	22,0	110,0	-	90,0	4	A M6x7,5 T15F	T15F	A06.L A06.R
6,0	23,0	A06.0023	AAMQ	21,0	23,0	110,0	-	90,0	2	A M6x7,5 T15F	T15F	A06.L A06.R
6,0	25,0	A06.0025	AGFG	23,0	25,0	110,0	-	90,0	2	A M6x7,5 T15F	T15F	A06.L A06.R
6,0	25,4	A06.1.000	AFYZ	23,4	25,4	110,0	-	90,0	4	A M6x7,5 T15F	T15F	A06.L A06.R <small>inch</small>

Verwandte Werkzeuge finden Sie auch auf der folgenden Seite!
Related items can be found on the following page as well!

Fortgesetzte Tabelle
Continued Table

Bestellbeispiel // Order example: **A06.0016**