

Klemmhalter, Innenbearbeitung

Schwingungsgedämpfter Hartmetall-Rundschaft mit innerer Kühlmittelzufuhr.

Toolholder, For Internal Applications

Anti-vibration solid carbide round shank toolholder with through coolant.

Anzugsmoment (Schraube) // Tightening torque (screw)

1,5 Nm

Bitte Hinweise im Anhang beachten // Please read add. notes

MASTER (Seite/Page 212)



Legende
Legend **213**



Scan
QR-Code

Oder besuchen Sie // Or Visit
www.simtek.info/cp/808

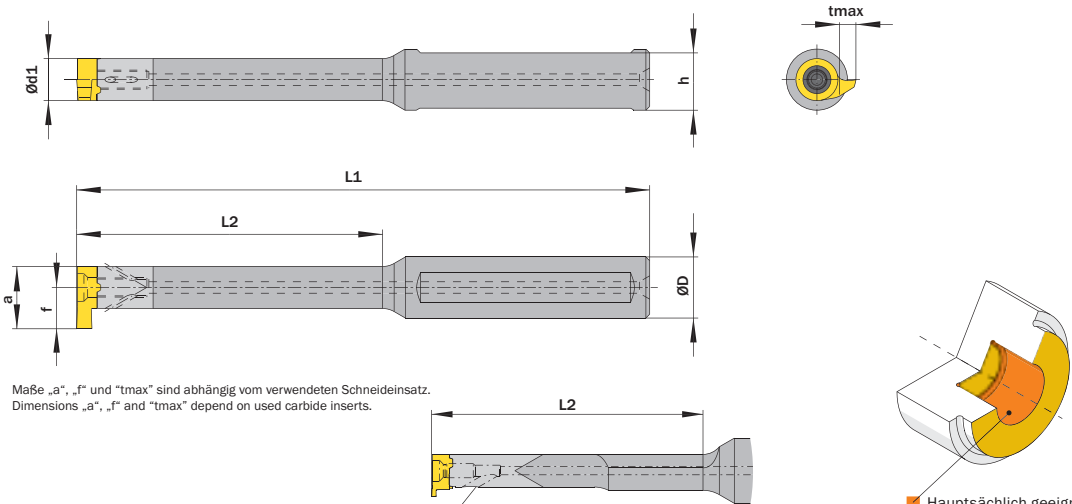

Maße „a“, „f“ und „tmax“ sind abhängig vom verwendeten Schneideinsatz.
Dimensions „a“, „f“ and „tmax“ depend on used carbide inserts.

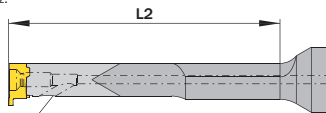

D08.0012.50 HM & D08.0.500.50 HM
Eine Kühlmittelzufuhr.
One through coolant supply.

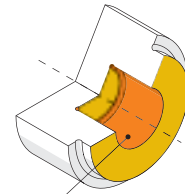

- Hauptsächlich geeignet für diese Flächen
Mainly designed for these surfaces
- Je nach Schneidplatte ebenfalls möglich
Also possible depending on insert type

Ød^{h6}	L2	Artikelnummer Part number	Webcode www.simtek.com/webcode	Ød1	h	L1	Schraube Screw	Schraubenschlüssel Screw driver	Connectcode www.simtek.com/code
mm	mm			mm	mm	mm			

Fortgesetzte Tabelle
Continued Table

Verwandte Werkzeuge finden Sie auch auf der vorhergehenden Seite!
Related items can be found on the previous page as well!

▼ ØD = 12,0 mm									
12,0	21,0	D08.0012.21 HM	AF03	6,0	11,5	80,0	D M2,6x8 T8F	T8F	D08
12,0	30,0	D08.0012.30 HM	AB7V	6,0	11,5	90,0	D M2,6x8 T8F	T8F	D08
12,0	42,0	D08.0012.42 HM	AAVA	6,0	11,5	100,0	D M2,6x8 T8F	T8F	D08
12,0	50,0	D08.0012.50 HM	AA9E	6,0	11,5	115,0	D M2,6x8 T8F	T8F	D08
▼ ØD = 12,7 mm									
12,7	21,0	D08.0.500.21 HM	AF99	6,0	12,2	80,0	D M2,6x8 T8F	T8F	D08 tipd
12,7	30,0	D08.0.500.30 HM	AEZK	6,0	12,2	90,0	D M2,6x8 T8F	T8F	D08 inch
12,7	42,0	D08.0.500.42 HM	AHCK	6,0	12,2	100,0	D M2,6x8 T8F	T8F	D08 inch
12,7	50,0	D08.0.500.50 HM	A5T1	6,0	12,2	115,0	D M2,6x8 T8F	T8F	D08 new inch

Verwandte Werkzeuge finden Sie auch auf der folgenden Seite!
Related items can be found on the following page as well!

Fortgesetzte Tabelle
Continued Table

Bestellbeispiel // Order example: **D08.0012.30 HM**