

Gewindedrehen, UNC/UNF, Innen, Vollprofil

Herstellung des vollständigen Gewindeprofils mit notwendiger Tiefe.

Threading, UNC/UNF, Internal, Full Profile

For a complete thread profile with correct depth.

Schnittwerte (Start) // Cutting parameters (start)
Anzahl Durchgänge // Number of passes 10 - 16
Empf. Zustellungsart // Recom. infeed method Flankenzustellung // Flank infeed (Seite/Page 433)
Vc Seite/Page 429
Passende Klemmhalter auf Seite // Suitable toolholders on page 27, 28, 31, 32, 33, 34, 35, 36, 40, 41, 42, 43, 44, 45, 50, 51, 53, 55, 56, 57, 58, 60, 61, 62, 63, 64, 65, 66, 67, 68, 69

SP

HM

R

Legende
Legend **139**

Scan
QR-Code

Oder besuchen Sie // Or Visit
www.simtek.info/cp/775



Abbildung zeigt / Drawing shows: A04.UN14.02.15.62 M R

Mehr Informationen zur Kühlmittelzufuhr finden Sie auf Seite 22
Additional information about through coolant supply on page 22

ØD	Gang/Zoll Threads/Inch	L2	Kühlmittelzufuhr Through coolant supply	Artikelnummer Part number	Webcode www.simtek.com/webcode	Unsere erste Wahl Our first choice	a	d	ØDmin (Min. Bohrung) ØDmin (min. bore)	f	H1	LH	Steigung (von) Pitch (as of)	S	w	Connectcode www.simtek.com/code
▼ ØDmin (Min. Bohrung) // ØDmin (min. bore) = 3,9 mm																
4,0	28	15,2	+	A04.UN28.02.15.39 MR/L	R AW98 L AD3Q	X800 X400	3,75	2,95	3,9	1,85	0,49	18,0	0,91	0,6	0,11	R A04C.R L A04C.L
4,0	32	15,2	+	A04.UN32.02.15.39 MR/L	R AW97 L AXA2	X800 X400	3,75	2,95	3,9	1,85	0,43	18,0	0,79	0,55	0,1	R A04C.R L A04C.L
▼ ØDmin (Min. Bohrung) // ØDmin (min. bore) = 4,2 mm																
4,0	24	15,2	+	A04.UN24.02.15.42 MR/L	R ACKF L AAPQ	X800 X400	3,95	3,05	4,2	1,95	0,57	18,0	1,06	0,65	0,13	R A04C.R L A04C.L
▼ ØDmin (Min. Bohrung) // ØDmin (min. bore) = 5,2 mm																
5,0	20	15,2	+	A05.UN20.02.15.52 MR/L	R AJXH L ATV1	X800 X400	4,95	3,95	5,2	2,45	0,69	18,0	1,27	0,7	0,16	R A05.R L A05.L
▼ ØDmin (Min. Bohrung) // ØDmin (min. bore) = 6,2 mm																
6,0	14	15,2	+	A06.UN14.02.15.62 MR/L	R AGVT L AEVU	X800 X400	5,95	4,55	6,2	2,95	0,98	18,0	1,81	0,9	0,23	R A06.R L A06.L
6,0	16	15,2	+	A06.UN16.02.15.62 MR/L	R AMTC L AGN9	X800 X400	5,95	4,75	6,2	2,95	0,86	18,0	1,59	0,85	0,2	R A06.R L A06.L
6,0	18	15,2	+	A06.UN18.02.15.62 MR/L	R AK2J L AFD2	X800 X400	5,95	4,85	6,2	2,95	0,76	18,0	1,41	0,75	0,18	R A06.R L A06.L

Bestellbeispiel // Order example: **A05.UN20.02.15.52 MR X800** (R = Rechte Ausführung // Right hand version, X800 = Schneidstoff // Grade)

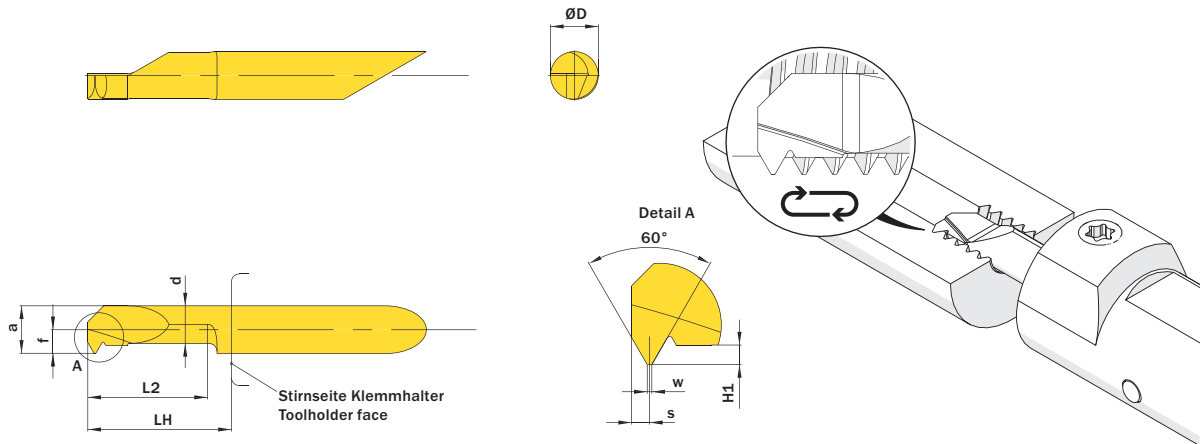
simturn AX
simturn DX
simturn PX
simturn H2
simturn K2
simturn C4
simturn GX
simturn E3
simturn E12
simturn FX
simturn Decollette
simturn OA
Index