

Nutenstechen

Für allgemeines Nutenstechen und für Sicherungsringnuten.
Geeignet ab Bohrungsdurchmesser 16,0 mm.

Grooving

For general grooving as well as for circlip ring grooving.
For use in bores as of minimum bore diameter 16,0 mm.

Schnittwerte (Start) // Cutting parameters (start)	
f 0,02 mm/U	Vc Seite/Page 429

Passende Klemmhalter auf Seite // Suitable toolholders on page
159, 163

Vergleichbare Werkzeuge auf Seite // Similar tools on page
175

SP **SP**
CBN **HM**

Scan QR-Code

R Legende
Legend **213**

Oder besuchen Sie // Or Visit
www.simtek.info/cp/842



Abbildung zeigt / Drawing shows: D16.0200.00 G R

w ^{+0,03}	Nutnenbreite Nominal width of groove	ØDmin (Min. Bohrung) ØDmin (min. bore)	Artikelnummer Part number	Webcode www.simtek.com/webcode	Unsere erste Wahl Our first choice	a	Ød	f	R	S	tmax	Connectcode www.simtek.com/code
mm	mm	mm			P K M N S	mm	mm	mm	mm	mm	mm	

Fortgesetzte Tabelle
Continued Table

Verwandte Werkzeuge finden Sie auch auf der vorhergehenden Seite!
Related items can be found on the previous page as well!

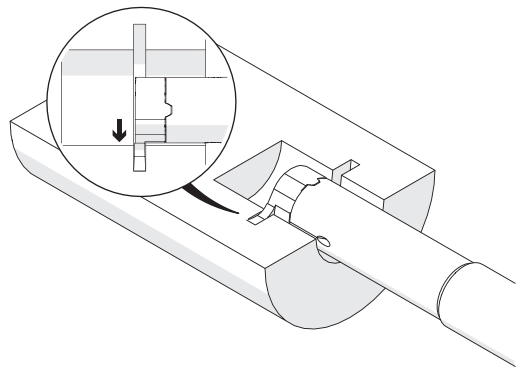
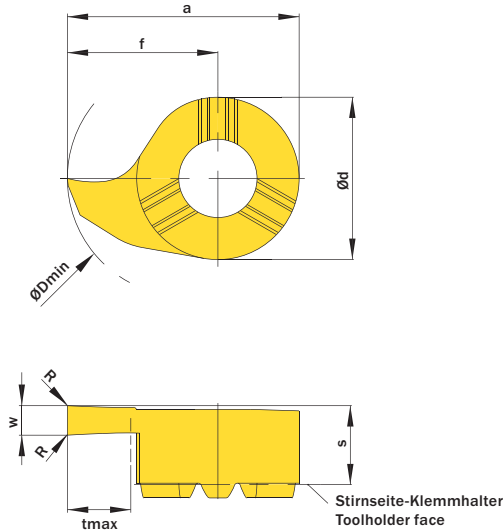
0,73	0,7	16,0	D16.0070.00 ZR/L	R AF7C L AN2X <u>X800</u> X400	15,7	11,0	10,2	-	5,2	1,2	D16
0,787	-	16,0	D16.0078.00 ZR/L	R AMHC L AHKC <u>X800</u> X400	15,7	11,0	10,2	-	5,2	1,3	D16
0,83	0,8	16,0	D16.0080.00 ZR/L	R AATC L AFUU <u>X800</u> X400	15,7	11,0	10,2	-	5,2	1,3	D16
0,93	0,9	16,0	D16.0090.00 ZR/L	R ADHV L ABYM <u>X800</u> X400	15,7	11,0	10,2	-	5,2	1,5	D16
1,0	1,0	16,0	D16.0100.00 ZR/L	R AHE1 L AMU9 <u>X800</u> X400	15,7	11,0	10,2	-	5,2	1,3	D16
1,2	1,1	16,0	D16.0110.00 GR/L	R AKCH L AGF2 <u>X800</u> X400	15,7	11,0	10,2	-	5,4	4,3	D16
1,4	1,3	16,0	D16.0130.00 GR/L	R AEQ6 L ADJ0 <u>X800</u> X400	15,7	11,0	10,2	-	5,4	4,3	D16
1,5	-	16,0	D16.0150.00 GR/L	R AEX2 L ACK6 <u>X800</u> X400	15,7	11,0	10,2	-	5,4	4,3	D16
1,575	-	16,0	D16.0157.00 GR/L	R APGQ L AHAE <u>X800</u> X400	15,7	11,0	10,2	-	5,4	4,3	D16
1,7	1,6	16,0	D16.0160.00 GR/L	R ANNC L AGBT <u>X800</u> X400	15,7	11,0	10,2	-	5,4	4,3	D16
2,0	-	16,0	D16.0200.00 GR/L	R ACXX L APFT <u>X800</u> X400	15,7	11,0	10,2	-	5,4	4,3	D16
2,5	-	16,0	D16.0250.00 GR/L	R AAMN L AA16 <u>X800</u> X400	15,7	11,0	10,2	-	5,4	4,3	D16
3,0	-	16,0	D16.0300.00 GR/L	R AHSW L AHXD <u>X800</u> X400	15,7	11,0	10,2	-	5,4	4,3	D16
3,5	-	16,0	D16.0350.00 GR/L	R ADH9 L AFEH <u>X800</u> X400	15,7	11,0	10,2	-	5,4	4,3	D16
4,0	-	16,0	D16.0400.00 GR/L	R ACJ0 L AE9X <u>X800</u> X400	15,7	11,0	10,2	-	5,4	4,3	D16

Verwandte Werkzeuge finden Sie auch auf der folgenden Seite!
Related items can be found on the following page as well!

Fortgesetzte Tabelle
Continued Table

Bestellbeispiel // Order example: **D16.0150.00 GR X800** (R = Rechte Ausführung // Right hand version, X800 = Schneidstoff // Grade)