

Nutenstechen

Geeignet ab Bohrungsdurchmesser 7,2 mm.

Grooving

For use in bores as of minimum bore diameter 7,2 mm.

Schnittwerte (Start) // Cutting parameters (start)

f	Vc
0,02 mm/U	Seite/Page 429

Passende Klemmhalter auf Seite // Suitable toolholders on page
29, 31, 37, 42, 46, 52, 54, 56, 58,
61, 64, 65, 66, 67, 68, 69

Vergleichbare Werkzeuge auf Seite // Similar tools on page
102



Legende
Legend 139

Scan QR-Code Oder besuchen Sie // Or Visit
www.simtek.info/cp/800

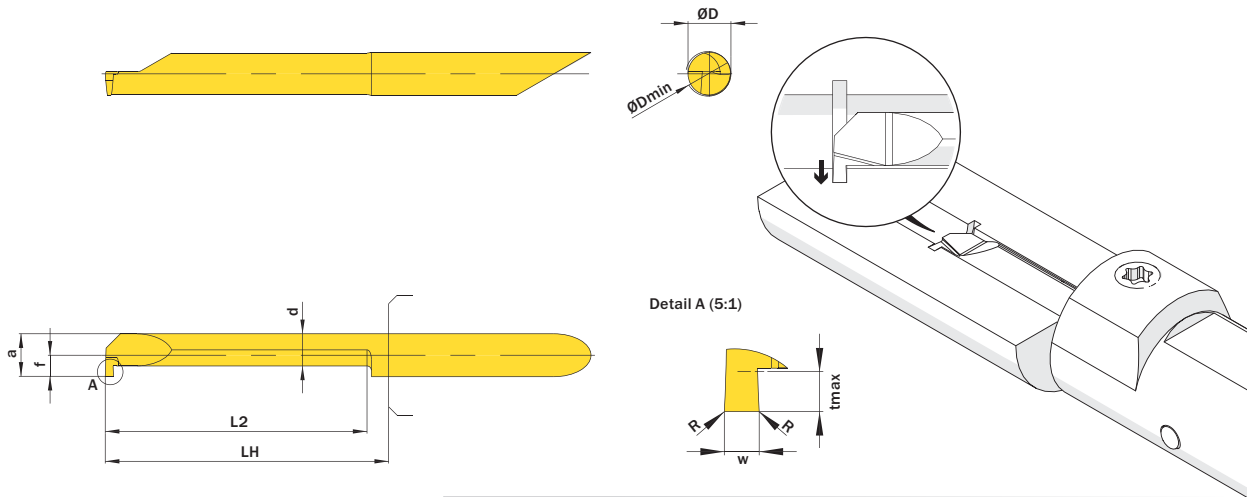

Mehr Informationen zur Kühlmittelzufuhr finden Sie auf Seite 22
Additional information about through coolant supply on page 22

ØD	w ^{+0,03}	L2	ØDmin (Min. Bohrung) ØDmin (min. bore)	Kühlmittelzufuhr Through coolant supply	Artikelnummer Part number	Webcode www.simtek.com/webcode	Unsere erste Wahl Our first choice	a	d	f	LH	R	tmax	Connectcode www.simtek.com/code
mm	mm	mm	mm				P K M N S	mm	mm	mm	mm	mm	mm	

Fortgesetzte Tabelle
Continued Table

Verwandte Werkzeuge finden Sie auch auf der vorhergehenden Seite!
Related items can be found on the previous page as well!

▼ w = 1,0 mm																
7,0	1,0	10,2	7,2	+	A07.0100.10.72 GR/L	R AJW1	L AJHP	X800 X400	6,95	4,25	3,45	13,0	-	2,5	R A07.R L A07.L	
7,0	1,0	15,2	7,2	+	A07.0100.15.72 GR/L	R AKT1	L AD20	X800 X400	6,95	4,25	3,45	18,0	-	2,5	R A07.R L A07.L	
7,0	1,0	20,3	7,2	+	A07.0100.20.72 GR/L	R AJ70	L AB35	X800 X400	6,95	4,25	3,45	23,0	-	2,5	R A07.R L A07.L	
7,0	1,0	25,4	7,2	+	A07.0100.25.72 GR/L	R APYK	L AN70	X800 X400	6,95	4,25	3,45	28,0	-	2,5	R A07.R L A07.L	
7,0	1,0	30,5	7,2	+	A07.0100.30.72 GR/L	R AA78	L ADG6	X800 X400	6,95	4,25	3,45	33,0	-	2,5	R A07.R L A07.L	
7,0	1,0	35,6	7,2	+	A07.0100.35.72 GR/L	R AKNF	L AFWS	X800 X400	6,95	4,25	3,45	38,0	-	2,5	R A07.R L A07.L	
7,0	1,0	40,6	7,2	+	A07.0100.40.72 GR/L	R ADSJ	L AHQJ	X800 X400	6,95	4,25	3,45	43,0	-	2,5	R A07.R L A07.L	
▼ w = 1,168 mm																
7,0	1,168	10,2	7,2	+	A07.0117.10.72 GR/L	R AA4H	L AJAH	X800 X400	6,95	4,25	3,45	13,0	-	2,5	R A07.R L A07.L	Inch
7,0	1,168	15,2	7,2	+	A07.0117.15.72 GR/L	R ADV1	L AHJH	X800 X400	6,95	4,25	3,45	18,0	-	2,5	R A07.R L A07.L	Inch
7,0	1,168	20,3	7,2	+	A07.0117.20.72 GR/L	R AHVD	L AE3M	X800 X400	6,95	4,25	3,45	23,0	-	2,5	R A07.R L A07.L	Inch
7,0	1,168	25,4	7,2	+	A07.0117.25.72 GR/L	R ANSE	L ANPE	X800 X400	6,95	4,25	3,45	28,0	-	2,5	R A07.R L A07.L	Inch
7,0	1,168	30,5	7,2	+	A07.0117.30.72 GR/L	R AKKW	L AB8D	X800 X400	6,95	4,25	3,45	33,0	-	2,5	R A07.R L A07.L	Inch
7,0	1,168	35,6	7,2	+	A07.0117.35.72 GR/L	R APF9	L AMQA	X800 X400	6,95	4,25	3,45	38,0	-	2,5	R A07.R L A07.L	Inch
7,0	1,168	40,6	7,2	+	A07.0117.40.72 GR/L	R AFTZ	L AEM7	X800 X400	6,95	4,25	3,45	43,0	-	2,5	R A07.R L A07.L	Inch

Verwandte Werkzeuge finden Sie auch auf der folgenden Seite!
Related items can be found on the following page as well!

Fortgesetzte Tabelle
Continued Table

Bestellbeispiel // Order example: A07.0100.10.72 GR X800 (R = Rechte Ausführung // Right hand version, X800 = Schneidstoff // Grade)