

Vorstechen und Fasen

Geeignet ab Bohrungsdurchmesser 8,0 mm.

Pre-Part-Off and Chamfering

For use in bores as of minimum bore diameter 8,0 mm.

Schnittwerte (Start) // Cutting parameters (start)

f	Vc
0,02 mm/U	Seite/Page 429

Passende Klemmhalter auf Seite // Suitable toolholders on page

154, 155, 156, 157, 158, 159, 161, 163, 164



SP
HM
R

Legende
Legend 213

Scan
QR-Code

Oder besuchen Sie // Or Visit
www.simtek.info/cp/831

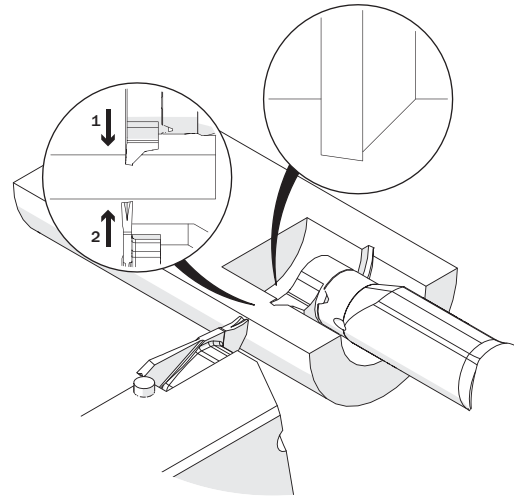
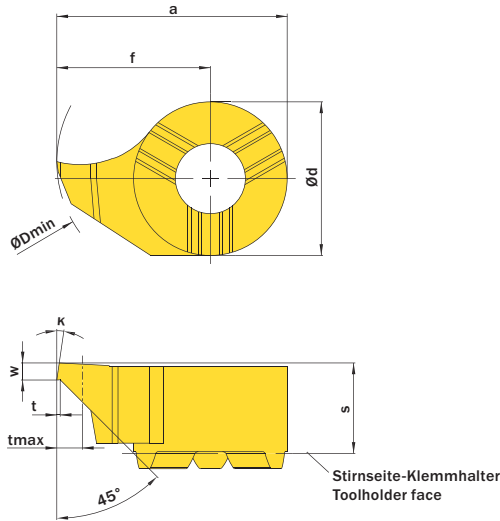

Abbildung zeigt / Drawing shows: D14.0810.00 P R

K	w mm	Artikelnummer Part number	Webcode www.simtek.com/webcode	Unsere erste Wahl Our first choice	a	Ød	ØDmin (Min. Bohrung) ØDmin (min. bore)	f	S	t	tmax	Connectcode www.simtek.com/code
▼ ØDmin (Min. Bohrung) // ØDmin (min. bore) = 8,0 mm												
8°	1,0	D08.0810.00 PR/L	R AJ7Z L AD30	X800 X400	7,8	6,0	8,0	4,8	3,3	0,2	1,0	D08
▼ ØDmin (Min. Bohrung) // ØDmin (min. bore) = 9,0 mm												
8°	1,0	D09.0810.00.09 PR/L	R AWF9 L AWHP	X800 X400	8,6	6,2	9,0	5,5	3,6	0,2	1,5	D09
▼ ØDmin (Min. Bohrung) // ØDmin (min. bore) = 10,0 mm												
8°	1,0	D10.0810.00.10 PR/L	R AHZ3 L APNG	X800 X400	9,3	7,0	10,0	5,8	3,9	0,2	1,5	D10
▼ ØDmin (Min. Bohrung) // ØDmin (min. bore) = 11,0 mm												
8°	1,0	D11.0810.00 PR/L	R AFDK L AB2C	X800 X400	10,7	8,0	11,0	6,7	4,2	0,2	1,5	D11
8°	1,5	D11.0815.00 PR/L	R AK9Z L AA76	X800 X400	10,7	8,0	11,0	6,7	4,2	0,2	1,5	D11
▼ ØDmin (Min. Bohrung) // ØDmin (min. bore) = 14,0 mm												
8°	1,0	D14.0810.00 PR/L	R AH2J L AE1N	X800 X400	13,5	9,0	14,0	9,0	5,3	0,2	1,5	D14
8°	1,5	D14.0815.00 PR/L	R AEQG L AHY9	X800 X400	13,5	9,0	14,0	9,0	5,3	0,2	1,5	D14
▼ ØDmin (Min. Bohrung) // ØDmin (min. bore) = 16,0 mm												
8°	1,0	D16.0810.00 PR/L	R AHPB L AADS	X800 X400	15,7	11,0	16,0	10,2	5,4	0,2	1,5	D16
8°	1,5	D16.0815.00 PR/L	R AAHN L ANXC	X800 X400	15,7	11,0	16,0	10,2	5,4	0,2	1,5	D16

Bestellbeispiel // Order example: **D11.0810.00 PR X800** (R = Rechte Ausführung // Right hand version, X800 = Schneidstoff // Grade)