

Nut-, Trenn- und Schlitzfräsen

Nutfräsen gerader Nutformen.
 Geeignet ab Bohrungsdurchmesser 37,0 mm.

Groove and Key Way Milling

General groove milling.
 For use in bores as of minimum bore diameter 37,0 mm.

Schnittwerte (Start) // Cutting parameters (start)		
fzm	hmax	Vc
0,01 mm	0,02 mm	Seite/Page 638

Passende Klemmhalter auf Seite // Suitable toolholders on page
556, 557, 558, 559, 560, 561, 562, 563, 564

Vergleichbare Werkzeuge auf Seite // Similar tools on page
461

Bitte Hinweise im Anhang beachten // Please read add. notes

ALL (Seite/Page 645), H01 (Seite/Page 646), H05 (Seite/Page 648)

SP

Legende

HM

Legend

650

Scan QR-Code Oder besuchen Sie // Or Visit
www.simtek.info/cp/384

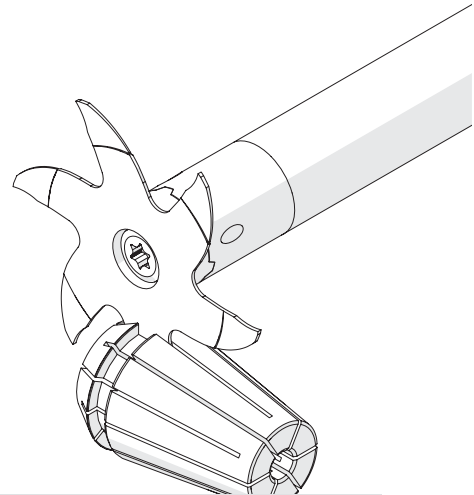
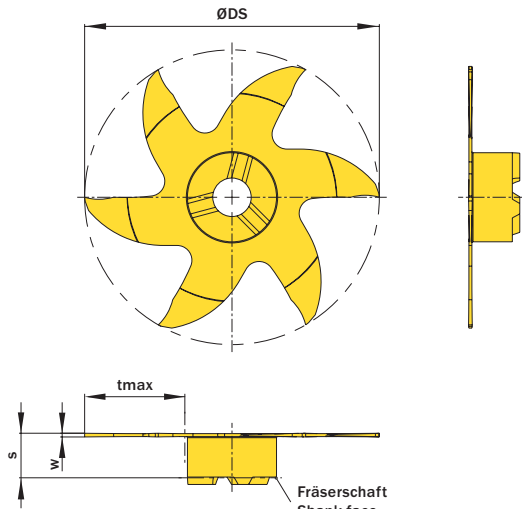

Illustration zeigt beispielhafte Anwendungsmöglichkeit mit ähnlichem Werkzeug.
 Image shows exemplary application possibility with similar tool.

Abbildung zeigt / Drawing shows: V06.0050.000.40 G

w ^{+0,05} mm	Nutnennbreite Nominal width of groove mm	R mm	ØDmin (Min. Bohrung) ØDmin (min. bore) mm	Artikelnummer Part number	Webcode www.simtek.com/webcode	Unsere erste Wahl Our first choice P M K N S	tmax mm	S mm	ØDS mm	Anzahl Schneiden Number of cutting edges	Connectcode www.simtek.com/code
▼ w = 0,4 mm											
0,4	-	-	40,0	V06.0040.000.40 G	AWAG	X800 GT42	13,5	6,0	39,7	6	VD12.0
▼ w = 0,5 mm											
0,5	-	-	37,0	V06.0050.000.37 G	AA6Ø	X800 GT42	12,0	6,0	36,7	6	VD12.0
0,5	-	-	40,0	V06.0050.000.40 G	AXBF	X800 GT42	13,5	6,0	39,7	6	VD12.0
▼ w = 0,6 mm											
0,6	-	-	37,0	V06.0060.000.37 G	AA5V	X800 GT42	12,0	5,7	36,7	6	VD12.0
0,6	-	-	40,0	V06.0060.000.40 G	AXBG	X800 GT42	13,5	5,7	39,7	6	VD12.0
▼ w = 0,8 mm											
0,8	-	-	37,0	V06.0080.000.37 G	AN39	X800 GT42	12,0	5,9	36,7	6	VD12.0
0,8	-	-	40,0	V06.0080.000.40 G	AXBH	X800 GT42	13,5	5,9	39,7	6	VD12.0

Bestellbeispiel // Order example: **V06.0080.000.37 G X800** (X800 = Schneidstoff // Grade)



V06. w, 1/100 mm, 4 Stellen/Digits . R, 1/100 mm, 3 Stellen/Digits .37 Toleranz // Tolerance
 Beispielpartikelnummer // Example Part number: **V06.0179.030.37 XG**