

Fräsen von Vollradiusnuten

Nutfräsen runder Nutformen.
Geeignet ab Bohrungsdurchmesser 12,0 mm.

Full Radius Groove Milling

Full radius groove milling.
For use in bores as of minimum bore diameter 12,0 mm.

Schnittwerte (Start) // Cutting parameters (start)

fzm 0,02 mm	hmax 0,03 mm	Vc Seite/Page 638
-----------------------	------------------------	-----------------------------

Passende Klemmhalter auf Seite // Suitable toolholders on page
485, 486, 487, 488, 489

Vergleichbare Werkzeuge auf Seite // Similar tools on page
465

Bitte Hinweise im Anhang beachten // Please read add. notes
ALL (Seite/Page 645), H01 (Seite/Page 646)



SP Legende
HM Legend **650**

Scan QR-Code Oder besuchen Sie // Or Visit
www.simtek.info/cp/400

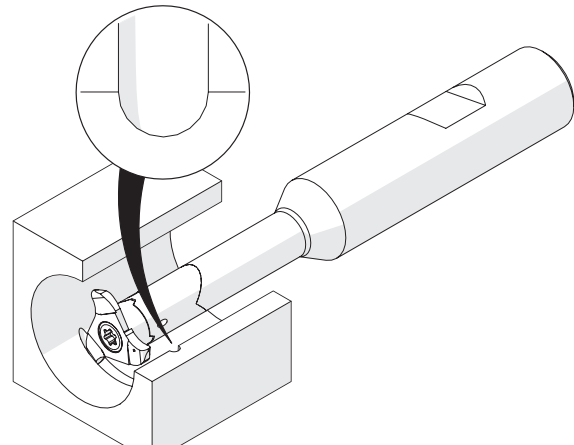
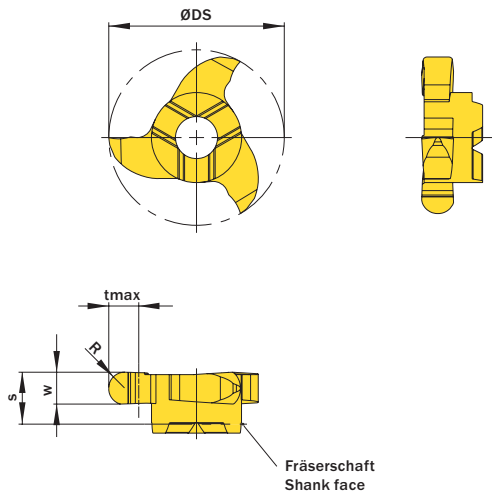

Illustration zeigt beispielhafte Anwendungsmöglichkeit mit ähnlichem Werkzeug.
Image shows exemplary application possibility with similar tool.

Abbildung zeigt / Drawing shows: P12.0011.22 V

R	w ^{+0,03}	ØDmin (Min. Bohrung) ØDmin (min. bore)	Artikelnummer Part number	Webcode www.simtek.com/webcode	Unsere erste Wahl Our first choice	tmax	S	ØDS	Anzahl Schneiden Number of cutting edges	Connectcode www.simtek.com/code	
mm	mm	mm			P M K N S	mm	mm	mm			
0,5	1,0	12,0	P12.0005.10 V	A6WH	X800 GT42	2,5	3,5	11,7	3	PD06.0	new
0,75	1,5	12,0	P12.0007.15 V	A6WK	X800 GT42	2,5	3,5	11,7	3	PD06.0	new
0,787	1,575	12,0	P12.0031.62 V	A3YN	X800 GT42	2,5	3,5	11,7	3	PD06.0	new
1,0	2,0	12,0	P12.0010.20 V	A6WN	X800 GT42	2,5	3,5	11,7	3	PD06.0	new
1,1	2,2	12,0	P12.0011.22 V	AC2H	X800 GT42	2,5	3,5	11,7	3	PD06.0	
1,194	2,388	12,0	P12.0047.94 V	A3C1	X800 GT42	2,5	3,5	11,7	3	PD06.0	new inch
1,5	3,0	12,0	P12.0015.30 V	A6WQ	X800 GT42	2,5	3,5	11,7	3	PD06.0	new

Bestellbeispiel // Order example: **P12.0011.22 V X800** (X800 = Schneidstoff // Grade)