

Allgemeines Nutfräsen

Nutfräsen gerader Nutformen.
 Geeignet ab Bohrungsdurchmesser 22,0 mm.

General Groove Milling

General groove milling.
 For use in bores as of minimum bore diameter 22,0 mm.

Schnittwerte (Start) // Cutting parameters (start)		
fzm 0,04 mm	hmax 0,05 mm	Vc Seite/Page 638
Passende Klemmhalter auf Seite // Suitable toolholders on page 556, 557, 558, 559, 560, 561, 562, 563, 564		
Vergleichbare Werkzeuge auf Seite // Similar tools on page 461		
Bitte Hinweise im Anhang beachten // Please read add. notes ALL (Seite/Page 645), H01 (Seite/Page 646), H05 (Seite/Page 648)		

SP Legende
HM Legend

Scan
 Oder besuchen Sie // Or Visit
www.simtek.info/cp/380

Legende Legend **650**

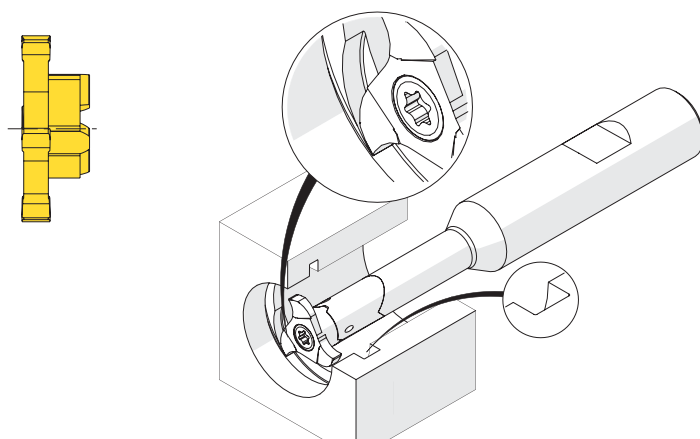
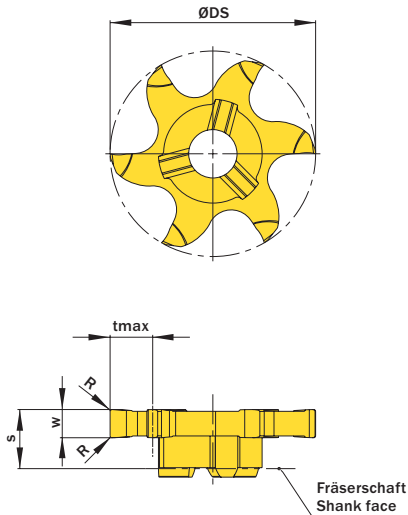

Illustration zeigt beispielhafte Anwendungsmöglichkeit mit ähnlichem Werkzeug.
 Image shows exemplary application possibility with similar tool.

Abbildung zeigt / Drawing shows: V06.0300.020.22 G

w ^{+0,02} mm	R mm	ØDmin (Min. Bohrung) ØDmin (min. bore) mm	Artikelnummer Part number	Webcode www.simtek.com/webcode	Unsere erste Wahl Our first choice	tmax mm	S mm	ØDS mm	Anzahl Schneiden Number of cutting edges	Connectcode www.simtek.com/code	
					P M K N S						
1,0	0,1	22,0	V06.0100.010.22 G	AGZW	X800 GT42	4,5	5,8	21,7	6	VD12.0	
1,168	0,1	22,0	V06.0117.010.22 G	A6EF	X800 GT42	4,5	5,8	21,7	6	VD12.0 <small>new inch</small>	
1,5	0,1	22,0	V06.0150.010.22 G	AGY6	X800 GT42	4,5	6,2	21,7	6	VD12.0	
1,575	0,1	22,0	V06.0157.010.22 G	A6EH	X800 GT42	4,5	6,2	21,7	6	VD12.0 <small>new inch</small>	
2,0	0,2	22,0	V06.0200.020.22 G	AFJQ	X800 GT42	4,5	6,2	21,7	6	VD12.0	
2,388	0,2	22,0	V06.0238.020.22 G	A6EB	X800 GT42	4,5	6,2	21,7	6	VD12.0 <small>new inch</small>	
2,5	0,2	22,0	V06.0250.020.22 G	AKJ5	X800 GT42	4,5	6,2	21,7	6	VD12.0	
3,0	0,2	22,0	V06.0300.020.22 G	AFBB	X800 GT42	4,5	6,2	21,7	6	VD12.0	
3,175	0,2	22,0	V06.0318.020.22 G	A6ED	X800 GT42	4,5	6,2	21,7	6	VD12.0 <small>new inch</small>	
4,0	0,2	22,0	V06.0400.020.22 G	APZW	X800 GT42	4,5	6,2	21,7	6	VD12.0	

Bestellbeispiel // Order example: **V06.0200.020.22 G X800** (X800 = Schneidstoff // Grade)



V06. w, 1/100 mm, 4 Stellen/Digits . R, 1/100 mm, 3 Stellen/Digits .22 Toleranz // Tolerance

Beispielartikelnummer // Example Part number: **V06.0179.030.22 XG**

simmill AX
simmill PMX
simmill PX
simmill SX
simmill UX
simmill VX
simmill H2
simmill K2
simmill MX
simmill OS
Index