

## Einstecken und Profildrehen

CNC-Konturdrehen mit gesinterter Spanformgeometrie für kontrollierte Spanbildung.

## Grooving and Profiling

CNC profiling. Sintered geometry for improved chip control.

Schnittwerte (Start) // Cutting parameters (start)

f (außen//ext.) <b>0,12 mm/U</b>	f (innen//int.) <b>0,09 mm/U</b>	Vc <b>Seite/Page 429</b>
-------------------------------------	-------------------------------------	-----------------------------

Passende Klemmhalter auf Seite // Suitable toolholders on page

**295, 296, 297, 298, 299, 300, 301, 302, 303**



**SP** Legende  
**HM** Legend

**315**

Scan QR-Code

Oder besuchen Sie // Or Visit  
[www.simtek.info/cp/521](http://www.simtek.info/cp/521)

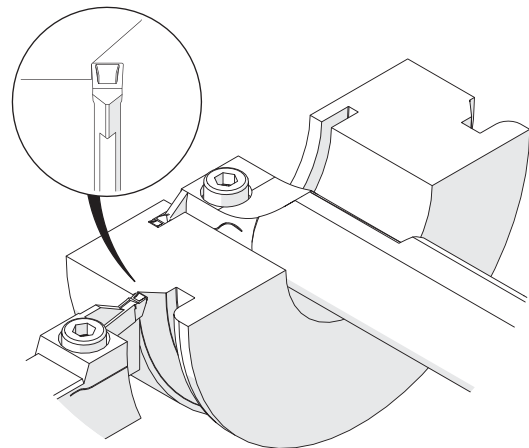
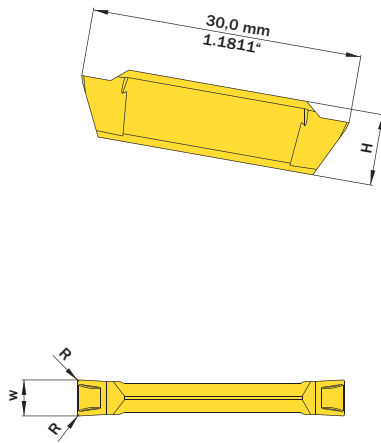

Abbildung zeigt / Drawing shows: G29.0400.32 S

w <sup>+0,05</sup> mm	R mm	Artikelnummer Part number	Webcode <a href="http://www.simtek.com/webcode">www.simtek.com/webcode</a>	Unsere erste Wahl Our first choice P K M N S	H mm	Connectcode <a href="http://www.simtek.com/code">www.simtek.com/code</a>
2,0	0,2	<b>G29.0200.32 S</b>	ABNM	X800 X400	7,9	G29.02
2,5	0,2	<b>G29.0250.32 S</b>	AHMB	X800 X400	7,9	G29.02
3,0	0,2	<b>G29.0300.32 S</b>	AFPT	X800 X400	7,9	G29.03
3,0	0,4	<b>G29.0300.34 S</b>	AN8A	X800 X400	7,9	G29.03
3,175	0,2	<b>G29.0318.32 S</b>	A6DD	X800 X400	7,9	G29.03
3,175	0,4	<b>G29.0318.34 S</b>	A6DF	X800 X400	7,9	G29.03
4,0	0,2	<b>G29.0400.32 S</b>	AJK1	X800 X400	7,9	G29.03   G29.04
4,0	0,4	<b>G29.0400.34 S</b>	AAE0	X800 X400	7,9	G29.03   G29.04
5,0	0,4	<b>G29.0500.34 S</b>	AN6E	X800 X400	7,9	G29.04
6,0	0,4	<b>G29.0600.34 S</b>	AE8G	X800 X400	7,5	G29.06
6,0	0,8	<b>G29.0600.38 S</b>	ANYA	X800 X400	7,5	G29.06
<b>6,35</b>	<b>0,2</b>	<b>G29.0635.32 S</b>	<b>A6DV</b>	<b>X800 X400</b>	<b>7,5</b>	<b>G29.06</b>
6,35	0,4	<b>G29.0635.34 S</b>	A6DT	X800 X400	7,5	G29.06

Bestellbeispiel // Order example: **G29.0300.34 S X800** (X800 = Schneidstoff // Grade)