

Stechen von Vollradiusnuten

Geeignet ab Bohrungsdurchmesser 8,0 mm.

Full Radius Grooving

For use in bores as of minimum bore diameter 8,0 mm.

Schnittwerte (Start) // Cutting parameters (start)

f	Vc
0,02 mm/U	Seite/Page 429

Passende Klemmhalter auf Seite // Suitable toolholders on page
154, 155, 163, 164

SP

HM

R

Legende
Legend

213

Scan
QR-Code

Oder besuchen Sie // Or Visit
www.simtek.info/cp/830

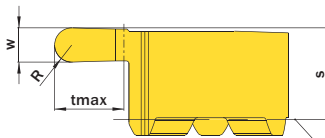
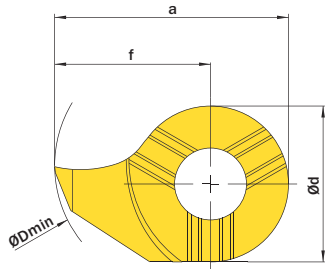

Stirnseite Klemmhalter
Toolholder face



Abbildung zeigt / Drawing shows: D14.0010.20 V R

R	w ^{+0,05}	Artikelnummer Part number	Webcode www.simtek.com/webcode	Unsere erste Wahl Our first choice	a	Ød	ØDmin (Min. Bohrung) ØDmin (min. bore)	s	f	tmax	Connectcode www.simtek.com/code
mm	mm			P K M N S	mm	mm	mm	mm	mm	mm	
▼ ØDmin (Min. Bohrung) // ØDmin (min. bore) = 8,0 mm											
0,4	0,8	D08.0004.08 VR/L	R AAP2	L AE8B X800 X400	7,8	6,0	8,0	3,3	4,8	1,0	D08
0,6	1,2	D08.0006.12 VR/L	R AHUE	L AF16 X800 X400	7,8	6,0	8,0	3,3	4,8	1,0	D08
0,79	1,575	D08.0008.157 VR/L	R A4NH	L A4NK X800 X400	7,8	6,0	8,0	3,3	4,8	1,0	D08
0,8	1,6	D08.0008.16 VR/L	R ANWU	L AJUP X800 X400	7,8	6,0	8,0	3,3	4,8	1,0	D08
0,9	1,8	D08.0009.18 VR/L	R AMHØ	L APZV X800 X400	7,8	6,0	8,0	3,3	4,8	1,0	D08
1,0	2,0	D08.0010.20 VR/L	R ADYE	L AEDC X800 X400	7,8	6,0	8,0	3,3	4,8	1,0	D08
▼ ØDmin (Min. Bohrung) // ØDmin (min. bore) = 9,0 mm											
0,4	0,8	D09.0004.08.09 VR/L	R AFFF	L AWGW X800 X400	8,6	6,2	9,0	3,5	5,5	1,6	D09
0,5	1,0	D09.0005.10.09 VR/L	R A5WV	L A5W3 X800 X400	8,6	6,2	9,0	3,5	5,5	1,6	D09
0,6	1,2	D09.0006.12.09 VR/L	R ACFG	L AWGX X800 X400	8,6	6,2	9,0	3,5	5,5	1,6	D09
0,9	1,8	D09.0009.18.09 VR/L	R AWFH	L AWGY X800 X400	8,6	6,2	9,0	3,5	5,5	1,6	D09
1,0	2,0	D09.0010.20.09 VR/L	R AWFJ	L AWGZ X800 X400	8,6	6,2	9,0	3,5	5,5	1,6	D09

Verwandte Werkzeuge finden Sie auch auf der folgenden Seite!
Related items can be found on the following page as well!

Fortgesetzte Tabelle
Continued Table

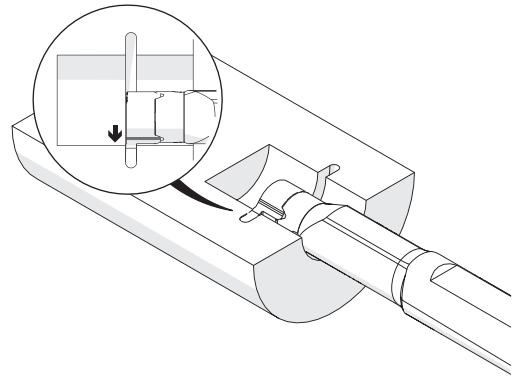
Bestellbeispiel // Order example: **D08.0004.08 VR X800** (R = Rechte Ausführung // Right hand version, X800 = Schneidstoff // Grade)