

Gewindedrehen, STUB-ACME Teilprofil

STUB-ACME Gewinde, Teilprofil, Innen.

Threading, STUB-ACME Partial Profile

STUB-ACME threads, partial profile, internal.

Schnittwerte (Start) // Cutting parameters (start)

f	Vc
0,02 mm/U	Seite/Page 429

Empf. Zustellungsart // Recom. infeed method
Flankenzustellung // Flank infeed (Seite/Page 433)

Passende Klemmhalter auf Seite // Suitable toolholders on page

27, 28, 29, 31, 33, 35, 36, 37, 41,
42, 44, 45, 46, 50, 51, 52, 53, 54,
55, 56, 57, 58, 61, 62, 63, 64, 65,
66, 67, 68, 69



Legende
Legend 139

Scan QR-Code Oder besuchen Sie // Or Visit
www.simtek.info/cp/1338



Abbildung zeigt / Drawing shows: A05.SA16.01.25.52 MR



Mehr Informationen zur Kühlmittelzufuhr finden Sie auf Seite 22
Additional information about through coolant supply on page 22

ØD	Gang/Zoll Threads/inch	L2	ØDmin (Min. Bohrung) ØDmin (min. bore)	Kühlmittelzufuhr Through coolant supply	Artikelnummer Part number	Webcode www.simtek.com/webcode	Unsere erste Wahl Our first choice	a	d	f	LH	S	t	Connectcode www.simtek.com/code	
mm		mm	mm				P K M N S	mm	mm	mm	mm	mm	mm		
5,0	16	25,4	5,2	+	A05.SA16.01.25.52 MR	A5A7	X800 X400	4,95	3,7	2,45	28,0	0,8	0,92	A05.R	new
6,0	14	25,4	6,2	+	A06.SA14.01.25.62 MR	A5A9	X800 X400	5,95	4,6	2,95	28,0	0,7	0,82	A06.R	new
7,0	10	30,5	7,2	+	A07.SA10.01.30.72 MR	A5BB	X800 X400	6,95	5,1	3,45	33,0	0,9	1,19	A07.R	new
7,0	12	30,5	7,2	+	A07.SA12.01.30.72 MR	A5BD	X800 X400	6,95	5,5	3,45	33,0	0,8	0,92	A07.R	new

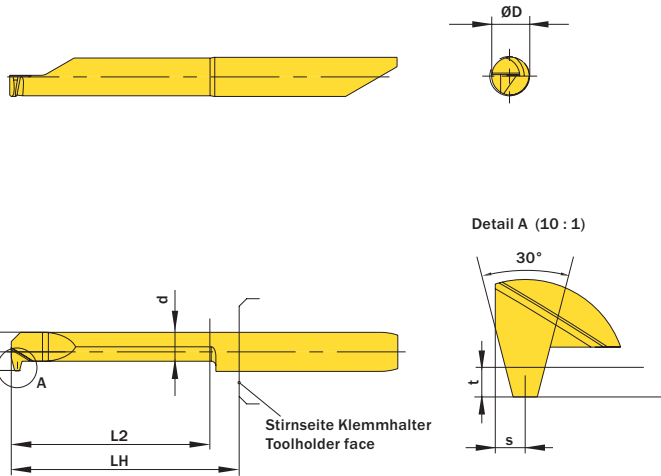
Bestellbeispiel // Order example: **A05.SA16.01.25.52 MR X800** (R = Rechte Ausführung // Right hand version, X800 = Schneidstoff // Grade)