

Kopieren / Profildrehen mit 32°

Geeignet ab Bohrungsdurchmesser 7,0 mm.

Copying / Profiling with 32°

For use in bores as of minimum bore diameter 7,0 mm.

Schnittwerte (Start) // Cutting parameters (start)

f **0,02 mm/U** Vc **Seite/Page 429**

Passende Klemmhalter auf Seite // Suitable toolholders on page

153, 154, 155, 156, 157, 158, 159, 161, 162, 163, 164



SP
HM
R

Legende
Legend **213**

Scan QR-Code Oder besuchen Sie // Or Visit www.simtek.info/cp/1336

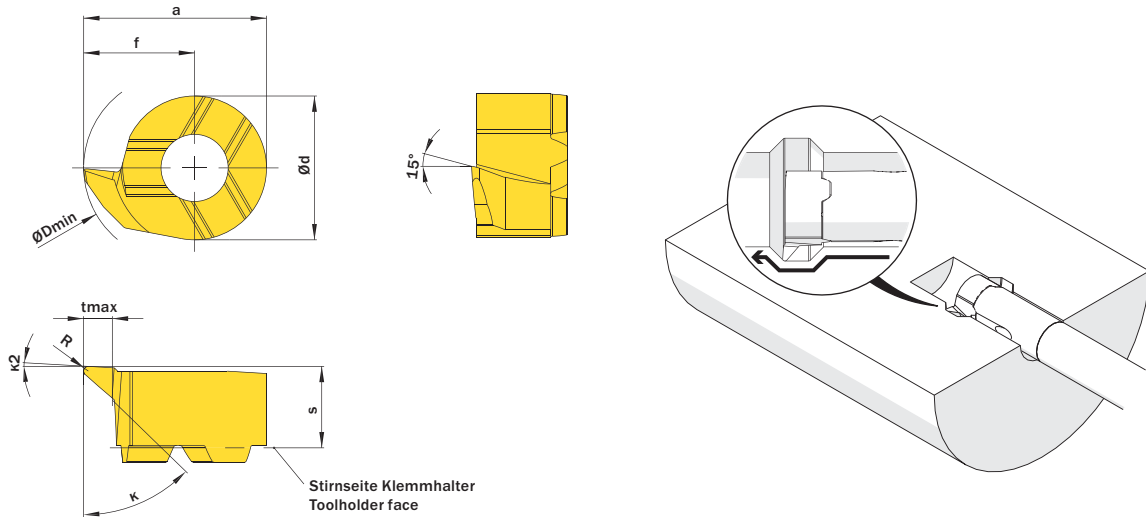

Abbildung zeigt / Drawing shows: D08.4746.02 Y R

ØDmin (Min. Bohrung) ØDmin (min. bore)	κ	κ2	f	R	Artikelnummer Part number	Webcode www.simtek.com/webcode	Unsere erste Wahl Our first choice	a	Ød	S	tmax	Connectcode www.simtek.com/code	
mm			mm	mm			P K M N S	mm	mm	mm	mm		
▼ ØDmin (Min. Bohrung) // ØDmin (min. bore) = 7,0 mm													
7,0	32°	3°	4,15	0,2	D07.3246.02 YR	A51B	X800 X400	6,55	4,8	3,5	1,2	D07	new
▼ ØDmin (Min. Bohrung) // ØDmin (min. bore) = 7,8 mm													
7,8	30°	5°	4,65	0,2	D08.2555.02 YR/L	R ADG0 L AFB6	X800 X400	7,65	6,0	3,5	1,0	D08	
7,8	32°	5°	4,65	0,4	D08.3246.04 YR	A51F	X800 X400	7,65	6,0	3,5	1,0	D08	new
▼ ØDmin (Min. Bohrung) // ØDmin (min. bore) = 9,0 mm													
9,0	32°	3°	5,5	0,2	D09.3255.02.09 YR	A51H	X800 X400	8,6	6,2	3,6	1,5	D09	new
▼ ØDmin (Min. Bohrung) // ØDmin (min. bore) = 10,0 mm													
10,0	32°	3°	5,8	0,2	D10.3258.02.10 YR	A51K	X800 X400	9,3	7,0	3,9	1,8	D10	new
▼ ØDmin (Min. Bohrung) // ØDmin (min. bore) = 11,0 mm													
11,0	30°	5°	6,7	0,2	D11.2755.02 YR/L	R AJ32 L AJHE	X800 X400	10,7	8,0	4,2	2,3	D11	
11,0	32°	5°	6,7	0,4	D11.3267.04 YR	A51N	X800 X400	10,7	8,0	4,2	2,3	D11	new
▼ ØDmin (Min. Bohrung) // ØDmin (min. bore) = 13,7 mm													
13,7	32°	5°	8,7	0,4	D14.3287.04 YR	A51Q	X800 X400	13,2	9,0	5,3	4,0	D14	new
13,7	30°	5°	8,7	0,2	D14.3555.02 YR/L	R ABCT L AACN	X800 X400	13,2	9,0	5,3	4,0	D14	
▼ ØDmin (Min. Bohrung) // ØDmin (min. bore) = 15,8 mm													
15,8	30°	5°	10,2	0,2	D16.4055.02 YR/L	R AJWM L AK73	X800 X400	15,7	11,0	5,4	4,3	D16	
▼ ØDmin (Min. Bohrung) // ØDmin (min. bore) = 16,0 mm													
16,0	32°	5°	11,0	0,2	D14.3210.02.16 YR	A51T	X800 X400	15,5	9,0	5,2	5,0	D14	new

Bestellbeispiel // Order example: **D08.2555.02 YR X800** (R = Rechte Ausführung // Right hand version, X800 = Schneidstoff // Grade)

simturn AX
simturn DX
simturn PX
simturn H2
simturn K2
simturn C4
simturn GX
simturn E3
simturn E12
simturn FX
simturn Decolletage
simturn OA
Index