

Kopieren / Profildrehen mit 32°

Geeignet ab Bohrungsdurchmesser 2,2 mm.

Copying / Profiling with 32°

For use in bores as of minimum bore diameter 2,2 mm.

Schnittwerte (Start) // Cutting parameters (start)

f	Vc
0,02 mm/U	Seite/Page 429

Passende Klemmhalter auf Seite // Suitable toolholders on page

26, 27, 28, 31, 32, 33, 34, 35, 36,
40, 41, 42, 43, 44, 45, 50, 51, 53,
55, 56, 57, 58, 60, 61, 62, 63, 64,
65, 66, 67, 68, 69



SP HM R Legende Legend 139
Scan QR-Code Oder besuchen Sie // Or Visit www.simtek.info/cp/1335



Abbildung zeigt / Drawing shows: A05.3225.25.52.15 Y R



Mehr Informationen zur Kühlmittelzufuhr finden Sie auf Seite 22
Additional information about through coolant supply on page 22

ØD	f	L2	ØDmin (Min. Bohrung) ØDmin (min. bore)	R	Kühlmittelzufuhr Through coolant supply	Artikelnummer Part number	Webcode www.simtek.com/webcode	Unsere erste Wahl Our first choice	a	d	LH	tmax	Connectcode www.simtek.com/code	
mm	mm	mm	mm	mm				P K M N S	mm	mm	mm	mm		
▼ ØDmin (Min. Bohrung) // ØDmin (min. bore) = 2,2 mm														
4,0	0,95	10,2	2,2	0,1	+	A04.3210.10.22.10 YR	A50N	X800 X400	1,95	1,35	13,0	0,4	A04.R A04C.R	new
▼ ØDmin (Min. Bohrung) // ØDmin (min. bore) = 2,7 mm														
4,0	1,2	15,2	2,7	0,1	+	A04.3212.15.27.10 YR	A50Q	X800 X400	2,45	1,75	18,0	0,5	A04.R A04C.R	new
▼ ØDmin (Min. Bohrung) // ØDmin (min. bore) = 3,2 mm														
4,0	1,45	15,2	3,2	0,1	+	A04.3215.15.32.10 YR	A50T	X800 X400	2,95	2,15	18,0	0,6	A04.R A04C.R	new
▼ ØDmin (Min. Bohrung) // ØDmin (min. bore) = 4,2 mm														
4,0	1,95	10,2	4,2	0,15	+	A04.3220.10.42.15 YR	A50V	X800 X400	3,95	2,95	13,0	0,8	A04C.R	new
4,0	1,95	20,3	4,2	0,15	+	A04.3220.20.42.15 YR	A50X	X800 X400	3,95	2,95	23,0	0,8	A04C.R	new
▼ ØDmin (Min. Bohrung) // ØDmin (min. bore) = 5,2 mm														
5,0	2,45	15,2	5,2	0,15	+	A05.3225.15.52.15 YR	A50Z	X800 X400	4,95	3,75	18,0	1,0	A05.R	new
5,0	2,45	25,4	5,2	0,15	+	A05.3225.25.52.15 YR	A501	X800 X400	4,95	3,75	28,0	1,0	A05.R	new
5,0	2,45	35,6	5,2	0,15	+	A05.3225.35.52.15 YR	A509	X800 X400	4,95	3,75	38,0	1,0	A05.R	new
▼ ØDmin (Min. Bohrung) // ØDmin (min. bore) = 6,2 mm														
6,0	2,95	20,3	6,2	0,15	+	A06.3230.20.62.15 YR	A503	X800 X400	5,95	3,95	23,0	1,8	A06.R	new
6,0	2,95	30,5	6,2	0,15	+	A06.3230.30.62.15 YR	A505	X800 X400	5,95	3,95	33,0	1,8	A06.R	new
6,0	2,95	40,6	6,2	0,15	+	A06.3230.40.62.15 YR	A507	X800 X400	5,95	3,95	43,0	1,8	A06.R	new

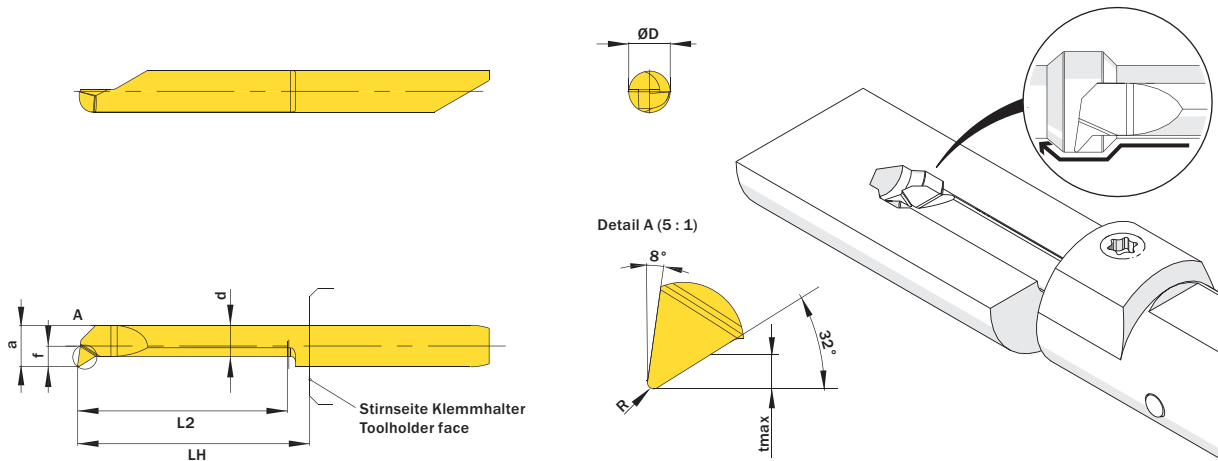
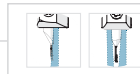
Bestellbeispiel // Order example: A06.3230.40.62.15 YR X800 (R = Rechte Ausführung // Right hand version, X800 = Schneidstoff // Grade)