

Axialstechen

Geeignet ab Bohrungsdurchmesser 3,0 mm.

Face Grooving

Inner diameter of groove starting at 3,0 mm.

Schnittwerte (Start) // Cutting parameters (start)	
f	Vc
0,02 mm/U	Seite/Page 429

Passende Klemmhalter auf Seite // Suitable toolholders on page
26, 31, 33, 34, 40, 41, 43, 50, 51, 53, 55, 56, 57, 60, 62, 63, 65, 66, 67, 68, 69

SP

HM

R

Legende
Legend

139

Scan
QR-Code

Oder besuchen Sie // Or Visit
www.simtek.info/cp/1378

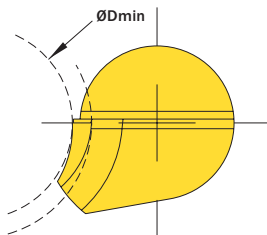
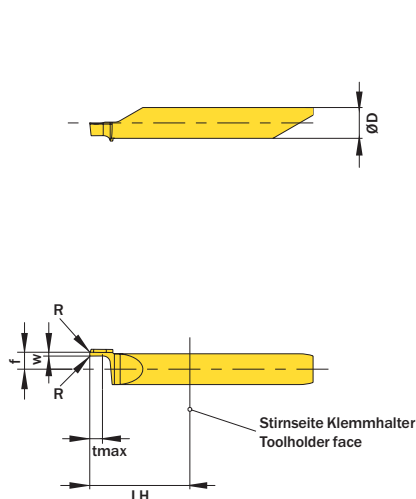

Achtung: Die Bearbeitung muss stets vom kleinsten Nutinnendurchmesser aus beginnen.
Attention: Machining process must always start at the smallest internal groove diameter.

Abbildung zeigt / Drawing shows: A04.56.0050.13.00 AG R

ØD	ab Nutinnendurchmesser as of inner groove diameter	w ^{+0,05}	LH	R	Artikelnummer Part number	Webcode www.simtek.com/webcode	Unsere erste Wahl Our first choice	f	tmax	Connectcode www.simtek.com/code
mm	mm	mm	mm	mm			P K M N S	mm	mm	
▼ ØDmin (Min. Bohrung) // ØDmin (min. bore) = 3,0 mm										
4,0	3,0	0,5	13,0	-	A04.34.0050.13.00 AG R	A2U4	X800 X400	2,2	1,6	A04.R new
▼ ØDmin (Min. Bohrung) // ØDmin (min. bore) = 4,0 mm										
4,0	4,0	0,5	13,0	-	A04.45.0050.13.00 AG R	A2U5	X800 X400	2,2	1,6	A04.R new
4,0	4,0	1,0	13,0	-	A04.46.0100.13.00 AG R	A2VA	X800 X400	2,2	3,3	A04.R new
▼ ØDmin (Min. Bohrung) // ØDmin (min. bore) = 5,0 mm										
4,0	5,0	0,5	13,0	-	A04.56.0050.13.00 AG R	A6K1	X800 X400	2,2	1,6	A04.R new

Bestellbeispiel // Order example: **A04.46.0100.13.00 AG R X800** (R = Rechte Ausführung // Right hand version, X800 = Schneidstoff // Grade)

simturn AX
simturn DX
simturn PX
simturn H2
simturn K2
simturn C4
simturn GX
simturn E3
simturn E12
simturn FX
simturn Decolletage
simturn OA
Index