

# Klemmhalter, Innenbearbeitung, Rundschaft, „ME“

Rundschaft aus Hartmetall, besonders geeignet zur Erhöhung der möglichen Auskragung mit unserem neuen ME-Spannprinzip. Das ME-Spannsystem bietet kraftschlüssiges Spannen und dadurch optimale Präzision und Stabilität. Vier Kühlmittelzufuhrarten je nach Bedarf einstellbar.

# Toolholder, Internal Applications, Round Shank „ME“

Carbide round shank, suitable for extending the overall tool reach equipped with our brand new ME-clamping system. The ME-system provides force-fitted clamping along with higher precision and stability. Four different types of through coolant supply can be realized as required.

Anzugsmoment (Schraube) // Tightening torque (screw)

**15,0 Nm - 25,0 Nm**

Bitte Hinweise im Anhang beachten // Please read add. notes

**MASTER (Seite/Page 137), T02 (Seite/Page 138)**

Scan QR-Code Oder besuchen Sie // Or Visit [www.simtek.info/cp/1276](http://www.simtek.info/cp/1276)

Legende Legend 139



Entdecken Sie unsere simturn AX Halter „ME“. Discover our simturn AX toolholder „ME“.

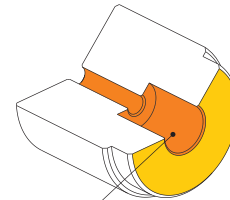
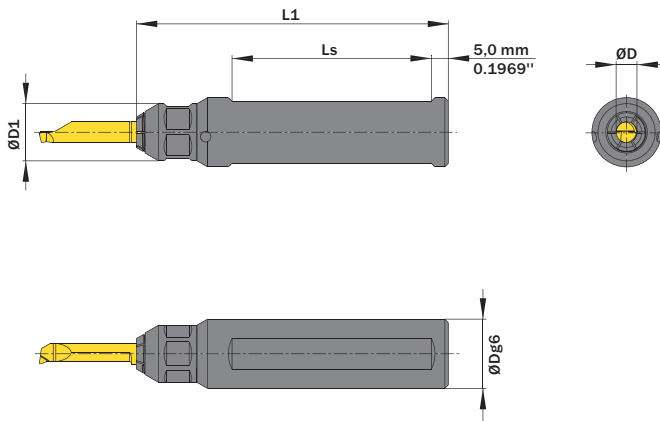

- Hauptsächlich geeignet für diese Flächen  
Mainly designed for these Surfaces
- Je nach Schneidplatte ebenfalls möglich  
Also possible depending on insert type

ØD	ØDg6	Artikelnummer Part number	Webcode www.simtek.com/webcode	ØD1	L1	Ls	Standard Mutter Standard screw nut	Connectcode www.simtek.com/code
mm	mm			mm	mm	mm		
8,0	15,875	<b>A08.0.625.ME IC</b>	A10N	19,0	75,0	42,0	A00.K.19.15.138	A08T <small>Inch</small>
8,0	16,0	<b>A08.0016.ME IC</b>	A10Q	19,0	75,0	42,0	A00.K.19.15.138	A08T
8,0	19,05	<b>A08.0.750.ME IC</b>	A10P	19,0	110,0	75,0	A00.K.19.15.138	A08T <small>Inch</small>
8,0	20,0	<b>A08.0020.ME IC</b>	A10S	19,0	110,0	75,0	A00.K.19.15.138	A08T
8,0	22,0	<b>A08.0022.ME IC</b>	A2TF	19,0	110,0	75,0	A00.K.19.15.138	A08T
8,0	25,0	<b>A08.0025.ME IC</b>	A10T	19,0	110,0	75,0	A00.K.19.15.138	A08T
8,0	25,4	<b>A08.1.000.ME IC</b>	A10U	19,0	110,0	75,0	A00.K.19.15.138	A08T <small>Inch</small>

Bestellbeispiel // Order example: **A08.0016.ME IC**

- Für Individual-Schneidwerkzeuge auch ab A04 erhältlich.
- For customized cutting tools also available as of size A04.