

# Axiale Gewindefreistiche

Geeignet für axiale Gewindefreistiche. Eingebaut unter 45°.

## Face Thread Reliefs

Suitable for thread reliefs. Mounted in a 45° toolholder.

Schnittwerte (Start) // Cutting parameters (start)

f	Vc
0,08 mm/U	Seite/Page 429

Passende Klemmhalter auf Seite // Suitable toolholders on page 395

SP

HM

L

Legende  
Legend

410

Scan  
QR-Code

Oder besuchen Sie // Or Visit  
[www.simtek.info/cp/1127](http://www.simtek.info/cp/1127)

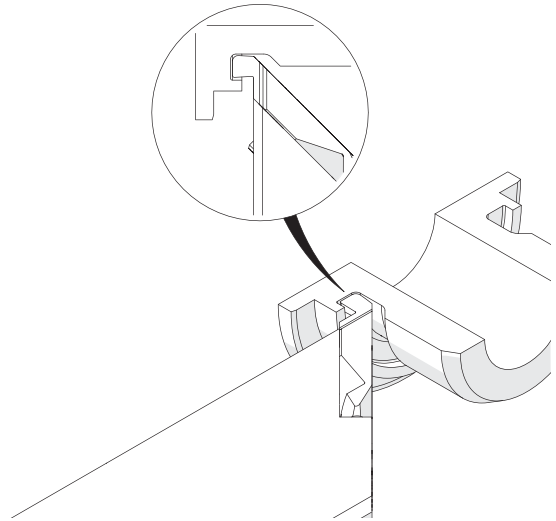
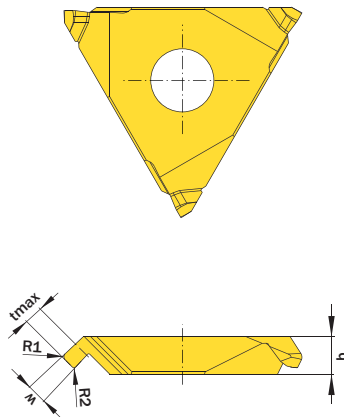

Abbildung zeigt / Drawing shows: TF3.00.0815.45.04 E L

ØDmin (Min. Bohrung) ØDmin (min. bore)	w	R1	Artikelnummer Part number	Webcode www.simtek.com/webcode	Unsere erste Wahl Our first choice				R2	b	tmax	Connectcode www.simtek.com/code
					P	K	M	S				
8,0	1,5	0,2	<b>TF3.00.0815.45.02 E R/L</b>	R A4TF	L A1GA	X800	X400	0,2	3,3	1,6	R TF3.L.45.00.03 L TF3.R.45.00.03 <b>new</b>	
8,0	1,5	0,4	<b>TF3.00.0815.45.04 E R/L</b>	R A4TH	L AYJV	X800	X400	0,2	3,3	1,6	R TF3.L.45.00.03 L TF3.R.45.00.03 <b>new</b>	
12,0	2,0	0,2	<b>TF3.00.1220.45.02 E R/L</b>	R A4TK	L A1EJ	X800	X400	0,2	3,3	2,0	R TF3.L.45.00.03 L TF3.R.45.00.03 <b>new</b>	
12,0	2,0	0,5	<b>TF3.00.1220.45.05 E R/L</b>	R A4TN	L AYJW	X800	X400	0,2	3,3	2,0	R TF3.L.45.00.03 L TF3.R.45.00.03 <b>new</b>	
20,0	2,4	0,6	<b>TF3.00.2024.45.06 E R/L</b>	R A4TQ	L AYJX	X800	X400	0,2	3,3	2,0	R TF3.L.45.00.03 L TF3.R.45.00.03 <b>new</b>	

Bestellbeispiel // Order example: **TF3.00.2024.45.06 E R X800** (R = Rechte Ausführung // Right hand version, X800 = Schneidstoff // Grade)

simturn AX  
simturn DX  
simturn PX  
simturn H2  
simturn K2  
simturn C4  
simturn GX  
simturn E3  
simturn E12  
simturn FX  
simturn Decolletage  
simturn OA  
Index