

Klemmhalter, Innenbearbeitung, Rundschaft, „ME“

Rundschaft aus Hartmetall, besonders geeignet zur Erhöhung der möglichen Auskragung mit unserem neuen ME-Spannprinzip. Das ME-Spannsystem bietet kraftschlüssiges Spannen und dadurch optimale Präzision und Stabilität. Vier Kühlmittelzufuhrarten je nach Bedarf einstellbar.

Toolholder, Internal Applications, Round Shank „ME“

Carbide round shank, suitable for extending the overall tool reach equipped with our brand new ME-clamping system. The ME-system provides force-fitted clamping along with higher precision and stability. Four different types of through coolant supply can be realized as required.

Anzugsmoment (Schraube) // Tightening torque (screw)

15,0 Nm - 25,0 Nm

Bitte Hinweise im Anhang beachten // Please read add. notes

MASTER (Seite/Page 137), T02 (Seite/Page 138)

TW ST ME Legende Legend 139
 Scan QR-Code Oder besuchen Sie // Or Visit www.simtek.info/cp/1164



Entdecken Sie unsere simturn AX Halter „ME“. Discover our simturn AX toolholder „ME“.

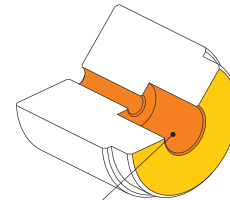
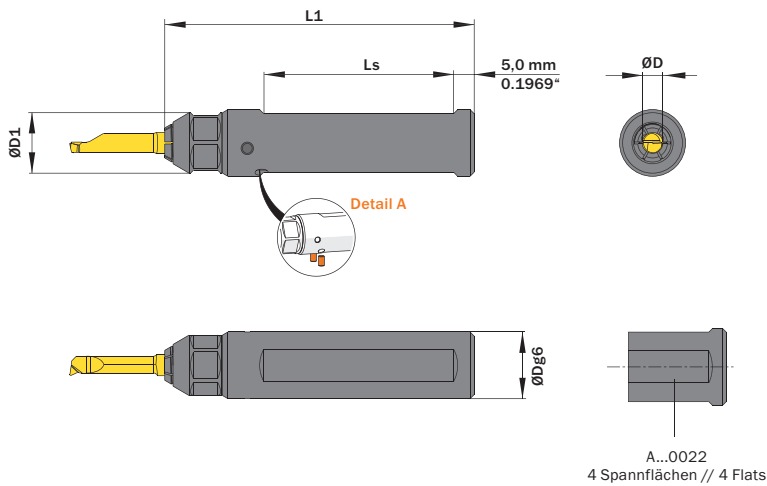

- **Hauptsächlich geeignet für diese Flächen**
Mainly designed for these surfaces
- **Je nach Schneidplatte ebenfalls möglich**
Also possible depending on insert type

Abbildung zeigt / Drawing shows: A04.0016.ME ST T

ØD	ØDg6	Artikelnummer Part number	Webcode www.simtek.com/webcode	ØD1	L1	Ls	Standard Mutter Standard screw nut	Connectcode www.simtek.com/code
mm	mm			mm	mm	mm		
4,0	12,0	A04.0012.ME ST T	AY7A	14,5	70,0	42,0	A00.K.14.12.88	A04.L A04.R A04CL A04C.R A04T
4,0	12,7	A04.0.500.ME ST T	A0YH	14,5	70,0	42,0	A00.K.14.12.88	
4,0	15,88	A04.0.625.ME ST T	AZN2	14,5	75,0	47,0	A00.K.14.12.88	
4,0	16,0	A04.0016.ME ST T	AY7B	14,5	75,0	47,0	A00.K.14.12.88	
4,0	19,05	A04.0.750.ME ST T	AZNH	14,5	110,0	78,0	A00.K.14.12.88	
4,0	20,0	A04.0020.ME ST T	AY7C	14,5	90,0	58,0	A00.K.14.12.88	
4,0	22,0	A04.0022.ME ST T	AZJ1	14,5	110,0	80,0	A00.K.14.12.88	
4,0	23,0	A04.0023.ME ST T	AZJ2	14,5	110,0	80,0	A00.K.14.12.88	
4,0	25,0	A04.0025.ME ST T	AY7D	14,5	110,0	80,0	A00.K.14.12.88	
4,0	25,4	A04.1.000.ME ST T	A0YY	14,5	110,0	80,0	A00.K.14.12.88	

Verwandte Werkzeuge finden Sie auch auf der folgenden Seite!
Related Items can be found on the following page as well!

Fortgesetzte Tabelle
Continued Table

Bestellbeispiel // Order example: **A04.0016.ME ST T**

Detail A | 1 Halter - 4 Kühlmittelzufuhrarten // 1 Toolholder - 4 types of coolant supply

