

Nutenstechen

Geeignet ab Bohrungsdurchmesser 6,2 mm.

Grooving

For use in bores as of minimum bore diameter 6,2 mm.

Schnittwerte (Start) // Cutting parameters (start)	
f 0,02 mm/U	Vc Seite/Page 421

Passende Klemmhalter auf Seite // Suitable toolholders on page
28, 29, 31, 36, 37, 42, 45, 46, 50, 51, 52, 53, 54, 55, 56, 58, 61, 62, 64, 65, 66, 67, 68, 69

Vergleichbare Werkzeuge auf Seite // Similar tools on page
102

SP **HM** **R** Legende Legend **139**

Scan QR-Code Oder besuchen Sie // Or Visit www.simtek.info/cp/799

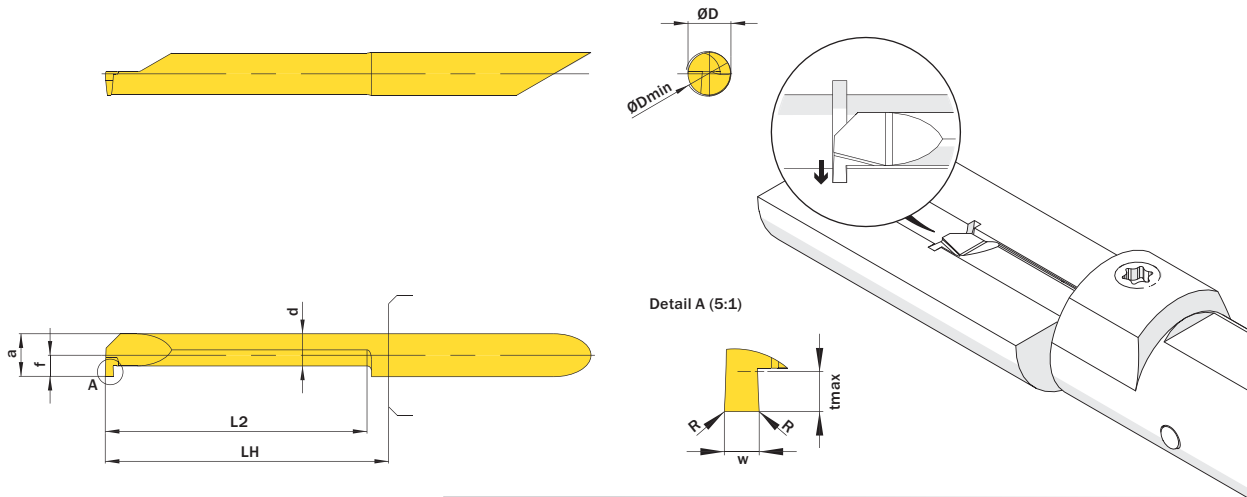

Mehr Informationen zur Kühlmittelzufuhr finden Sie auf Seite 22
Additional information about through coolant supply on page 22

ØD	w ^{+0,03}	L2	ØDmin (Min. Bohrung) / ØDmin (min. bore)	Kühlmittelzufuhr / Through coolant supply	Artikelnummer / Part number	Webcode / www.simtek.com/webcode	Unsere erste Wahl / Our first choice	a	d	f	LH	R	tmax	Connectcode / www.simtek.com/code
mm	mm	mm	mm				P K M N S	mm	mm	mm	mm	mm	mm	

Fortgesetzte Tabelle / Continued Table		Verwandte Werkzeuge finden Sie auch auf der vorhergehenden Seite! / Related items can be found on the previous page as well!													
6,0	1,981	10,2	6,2	+	A06.0198.10.62 GR/L	R AH4X L AJBE	X800 X400	5,95	3,95	2,95	13,0	-	1,8	R A06.R L A06.L	inch
6,0	1,981	15,2	6,2	+	A06.0198.15.62 GR/L	R AE9F L ANK9	X800 X400	5,95	3,95	2,95	18,0	-	1,8	R A06.R L A06.L	inch
6,0	1,981	20,3	6,2	+	A06.0198.20.62 GR/L	R AXVN L AFQQ	X800 X400	5,95	3,95	2,95	23,0	-	1,8	R A06.R L A06.L	inch
6,0	1,981	25,4	6,2	+	A06.0198.25.62 GR/L	R AJAX L AMQM	X800 X400	5,95	3,95	2,95	28,0	-	1,8	R A06.R L A06.L	inch
6,0	1,981	30,5	6,2	+	A06.0198.30.62 GR/L	R AJCJ L APFQ	X800 X400	5,95	3,95	2,95	33,0	-	1,8	R A06.R L A06.L	inch
6,0	1,981	30,5	6,2	+	A06.0198.30.62.10 GR	A6E9	X800 X400	5,95	3,95	2,95	33,0	0,1	1,8	A06.R	new inch
6,0	1,981	35,6	6,2	+	A06.0198.35.62 GR/L	R A08P L A08Q	X800 X400	5,95	3,95	2,95	38,0	-	1,8	R A06.R L A06.L	inch
6,0	2,0	10,2	6,2	+	A06.0200.10.62 GR/L	R ABY8 L AK2Q	X800 X400	5,95	3,95	2,95	13,0	-	1,8	R A06.R L A06.L	
6,0	2,0	15,2	6,2	+	A06.0200.15.62 GR/L	R AFYP L AEUP	X800 X400	5,95	3,95	2,95	18,0	-	1,8	R A06.R L A06.L	
6,0	2,0	20,3	6,2	+	A06.0200.20.62 GR/L	R AB0S L AHN0	X800 X400	5,95	3,95	2,95	23,0	-	1,8	R A06.R L A06.L	
6,0	2,0	25,4	6,2	+	A06.0200.25.62 GR/L	R APT6 L AC9V	X800 X400	5,95	3,95	2,95	28,0	-	1,8	R A06.R L A06.L	
6,0	2,0	30,5	6,2	+	A06.0200.30.62 GR/L	R AC74 L ANMU	X800 X400	5,95	3,95	2,95	33,0	-	1,8	R A06.R L A06.L	
7,0	0,787	10,2	7,2	+	A07.0078.10.72 GR/L	R ANFU L ACZM	X800 X400	6,95	4,25	3,45	13,0	-	2,5	R A07.R L A07.L	inch
7,0	0,787	15,2	7,2	+	A07.0078.15.72 GR/L	R AJB8 L AF8M	X800 X400	6,95	4,25	3,45	18,0	-	2,5	R A07.R L A07.L	inch
7,0	0,787	20,3	7,2	+	A07.0078.20.72 GR/L	R AG21 L ACUK	X800 X400	6,95	4,25	3,45	23,0	-	2,5	R A07.R L A07.L	inch
7,0	0,787	25,4	7,2	+	A07.0078.25.72 GR/L	R AJM7 L AM36	X800 X400	6,95	4,25	3,45	28,0	-	2,5	R A07.R L A07.L	inch
7,0	0,787	30,5	7,2	+	A07.0078.30.72 GR/L	R ABTA L APCD	X800 X400	6,95	4,25	3,45	33,0	-	2,5	R A07.R L A07.L	inch
7,0	0,787	35,6	7,2	+	A07.0078.35.72 GR/L	R ABGT L APCH	X800 X400	6,95	4,25	3,45	38,0	-	2,5	R A07.R L A07.L	inch
7,0	0,787	40,6	7,2	+	A07.0078.40.72 GR/L	R ANWX L AJ42	X800 X400	6,95	4,25	3,45	43,0	-	2,5	R A07.R L A07.L	inch

Verwandte Werkzeuge finden Sie auch auf der folgenden Seite! / Related items can be found on the following page as well!

Fortgesetzte Tabelle / Continued Table

Bestellbeispiel // Order example: **A06.0200.10.62 GR X800** (R = Rechte Ausführung // Right hand version, X800 = Schneidstoff // Grade)



A06.	w, 1/100 mm, 3 Stellen/Digits	L2, 1/1 mm, 2 Stellen/Digits	.52.	R, 1/100 mm, 3 Stellen/Digits	Toleranz // Tolerance	R/L
Beispielartikelnummer // Example Part number: A06.137.15.62.015 XN R oder // A06.137.15.62.015 XN L						
A07.	w, 1/100 mm, 3 Stellen/Digits	L2, 1/1 mm, 2 Stellen/Digits	.62.	R, 1/100 mm, 3 Stellen/Digits	Toleranz // Tolerance	R/L
Beispielartikelnummer // Example Part number: A07.137.15.72.015 XN R oder // A07.137.15.72.015 XN L						