

# Herstellen und Ausdrehen von Bohrungen

Schneideinsätze zum Herstellen und Ausdrehen von Bohrungen.  
Kühlmittelzufuhr durch die Schneide für eine optimale Spanabfuhr.

## Machining and Boring of Bores

Inserts for the machining and boring of bores.  
With coolant supply through the insert for an optimum chip evacuation.

Schnittwerte (Start) // Cutting parameters (start)	
f	Vc
0,02 mm/U	Seite/Page 429

Passende Klemmhalter auf Seite // Suitable toolholders on page  
33, 34, 35, 36, 37, 38, 41, 42, 43,  
44, 45, 46, 47, 49, 50, 51, 52, 53,  
54, 55, 59, 67, 68, 69

**SP** **HM** **R**

Legende Legend **139**

Scan QR-Code Oder besuchen Sie // Or Visit [www.simtek.info/cp/1260](http://www.simtek.info/cp/1260)

**1** Herstellen der Bohrung // Machining of the bore

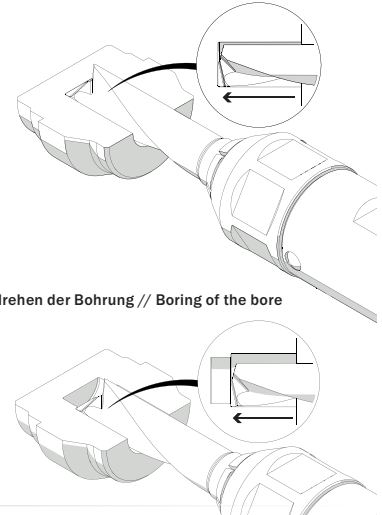
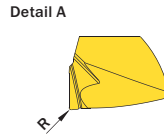
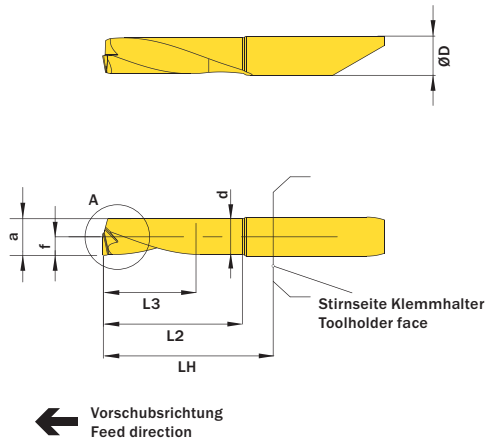

**2** Ausdrehen der Bohrung // Boring of the bore

Abbildung zeigt / Drawing shows: A07.DB34.25.70.20 YR

Mehr Informationen zur Kühlmittelzufuhr finden Sie auf Seite 22  
Additional information about through coolant supply on page 22

ØD	f	L2	R	Kühlmittelzufuhr Through coolant supply	Artikelnummer Part number	Webcode www.simtek.com/webcode	Unsere erste Wahl Our first choice	a	d	ØDCMIN	ØDCMAX	L3 (Max. Bohrungstiefe) L3 (max. depth of bore)	LH	Connectcode www.simtek.com/code
mm	mm	mm	mm				P K M N S	mm	mm	mm	mm	mm	mm	
<b>▼ ØDCMAX = 4,0 mm</b>														
4,0	1,85	15,2	0,15	+	A04.DB19.15.40.15 YR	A04Y	X800 X400	3,55	3,4	3,7	4,0	10,0	18,0	A04T
4,0	1,85	15,2	0,2	+	A04.DB19.15.40.20 YR	A038	X800 X400	3,55	3,4	3,7	4,0	10,0	18,0	A04T
4,0	1,85	20,3	0,2	+	A04.DB19.20.40.20 YR	A039	X800 X400	3,55	3,4	3,7	4,0	15,0	23,0	A04T
<b>▼ ØDCMAX = 5,0 mm</b>														
5,0	2,35	15,2	0,2	+	A05.DB24.15.50.20 YR	A031	X800 X400	4,55	4,4	4,7	5,0	10,0	18,0	A05T
5,0	2,35	20,3	0,2	+	A05.DB24.20.50.20 YR	A032	X800 X400	4,55	4,4	4,7	5,0	15,0	23,0	A05T
5,0	2,35	25,4	0,2	+	A05.DB24.25.50.20 YR	A04K	X800 X400	4,55	4,4	4,7	5,0	20,0	28,0	A05T
<b>▼ ØDCMAX = 6,0 mm</b>														
6,0	2,85	15,2	0,2	+	A06.DB29.15.60.20 YR	A033	X800 X400	5,55	5,4	5,7	6,0	10,0	18,0	A06T
6,0	2,85	20,3	0,2	+	A06.DB29.20.60.20 YR	A034	X800 X400	5,55	5,4	5,7	6,0	15,0	23,0	A06T
6,0	2,85	25,4	0,2	+	A06.DB29.25.60.20 YR	A04H	X800 X400	5,55	5,4	5,7	6,0	20,0	28,0	A06T
6,0	2,85	30,5	0,2	+	A06.DB29.30.60.20 YR	A04J	X800 X400	5,55	5,4	5,7	6,0	25,0	33,0	A06T
<b>▼ ØDCMAX = 7,0 mm</b>														
7,0	3,35	20,3	0,2	+	A07.DB34.20.70.20 YR	A035	X800 X400	6,55	6,4	6,7	7,0	15,0	23,0	A07T
7,0	3,35	25,4	0,2	+	A07.DB34.25.70.20 YR	A036	X800 X400	6,55	6,4	6,7	7,0	20,0	28,0	A07T
7,0	3,35	30,5	0,2	+	A07.DB34.30.70.20 YR	A037	X800 X400	6,55	6,4	6,7	7,0	25,0	33,0	A07T
<b>▼ ØDCMAX = 8,0 mm</b>														
8,0	3,85	20,3	0,2	+	A08.DB39.20.80.20 YR	A06W	X800 X400	7,55	7,4	7,7	8,0	15,0	23,0	A08T
8,0	3,85	25,4	0,2	+	A08.DB39.25.80.20 YR	A04F	X800 X400	7,55	7,4	7,7	8,0	20,0	28,0	A08T
8,0	3,85	30,5	0,2	+	A08.DB39.30.80.20 YR	A04G	X800 X400	7,55	7,4	7,7	8,0	25,0	33,0	A08T

Bestellbeispiel // Order example: **A06.DB29.15.60.20 YR X800** (R = Rechte Ausführung // Right hand version, X800 = Schneidstoff // Grade)