

Herstellen und Ausdrehen von Bohrungen

Schneideinsätze zum Herstellen und Ausdrehen von Bohrungen.
Kühlmittelzufuhr durch die Schneide für eine optimale Spanabfuhr.

Machining and Boring of Bores

Inserts for the machining and boring of bores.
With coolant supply through the insert for an optimum chip evacuation.

Schnittwerte (Start) // Cutting parameters (start)	
f	Vc
0,02 mm/U	Seite/Page 429

Passende Klemmhalter auf Seite // Suitable toolholders on page
33, 34, 35, 36, 37, 38, 41, 42, 43,
44, 45, 46, 47, 49, 50, 51, 52, 53,
54, 55, 59, 67, 68, 69

SP **HM** **R**

Legende Legend **139**

Scan QR-Code Oder besuchen Sie // Or Visit www.simtek.info/cp/1260

1 Herstellen der Bohrung // Machining of the bore

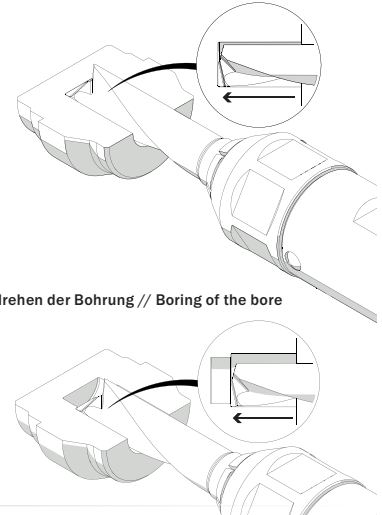
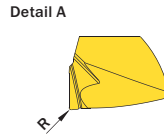
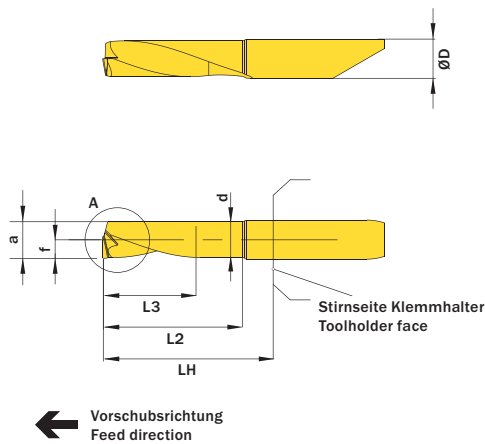

2 Ausdrehen der Bohrung // Boring of the bore

Abbildung zeigt / Drawing shows: A07.DB34.25.70.20 YR

Mehr Informationen zur Kühlmittelzufuhr finden Sie auf Seite 22
Additional information about through coolant supply on page 22

ØD	f	L2	R	Kühlmittelzufuhr Through coolant supply	Artikelnummer Part number	Webcode www.simtek.com/webcode	Unsere erste Wahl Our first choice	a	d	ØDCMIN	ØDCMAX	L3 (Max. Bohrungstiefe) L3 (max. depth of bore)	LH	Connectcode www.simtek.com/code
mm	mm	mm	mm				P K M N S	mm	mm	mm	mm	mm	mm	
▼ ØDCMAX = 4,0 mm														
4,0	1,85	15,2	0,15	+	A04.DB19.15.40.15 YR	A04Y	X800 X400	3,55	3,4	3,7	4,0	10,0	18,0	A04T
4,0	1,85	15,2	0,2	+	A04.DB19.15.40.20 YR	A038	X800 X400	3,55	3,4	3,7	4,0	10,0	18,0	A04T
4,0	1,85	20,3	0,2	+	A04.DB19.20.40.20 YR	A039	X800 X400	3,55	3,4	3,7	4,0	15,0	23,0	A04T
▼ ØDCMAX = 5,0 mm														
5,0	2,35	15,2	0,2	+	A05.DB24.15.50.20 YR	A031	X800 X400	4,55	4,4	4,7	5,0	10,0	18,0	A05T
5,0	2,35	20,3	0,2	+	A05.DB24.20.50.20 YR	A032	X800 X400	4,55	4,4	4,7	5,0	15,0	23,0	A05T
5,0	2,35	25,4	0,2	+	A05.DB24.25.50.20 YR	A04K	X800 X400	4,55	4,4	4,7	5,0	20,0	28,0	A05T
▼ ØDCMAX = 6,0 mm														
6,0	2,85	15,2	0,2	+	A06.DB29.15.60.20 YR	A033	X800 X400	5,55	5,4	5,7	6,0	10,0	18,0	A06T
6,0	2,85	20,3	0,2	+	A06.DB29.20.60.20 YR	A034	X800 X400	5,55	5,4	5,7	6,0	15,0	23,0	A06T
6,0	2,85	25,4	0,2	+	A06.DB29.25.60.20 YR	A04H	X800 X400	5,55	5,4	5,7	6,0	20,0	28,0	A06T
6,0	2,85	30,5	0,2	+	A06.DB29.30.60.20 YR	A04J	X800 X400	5,55	5,4	5,7	6,0	25,0	33,0	A06T
▼ ØDCMAX = 7,0 mm														
7,0	3,35	20,3	0,2	+	A07.DB34.20.70.20 YR	A035	X800 X400	6,55	6,4	6,7	7,0	15,0	23,0	A07T
7,0	3,35	25,4	0,2	+	A07.DB34.25.70.20 YR	A036	X800 X400	6,55	6,4	6,7	7,0	20,0	28,0	A07T
7,0	3,35	30,5	0,2	+	A07.DB34.30.70.20 YR	A037	X800 X400	6,55	6,4	6,7	7,0	25,0	33,0	A07T
▼ ØDCMAX = 8,0 mm														
8,0	3,85	20,3	0,2	+	A08.DB39.20.80.20 YR	A06W	X800 X400	7,55	7,4	7,7	8,0	15,0	23,0	A08T
8,0	3,85	25,4	0,2	+	A08.DB39.25.80.20 YR	A04F	X800 X400	7,55	7,4	7,7	8,0	20,0	28,0	A08T
8,0	3,85	30,5	0,2	+	A08.DB39.30.80.20 YR	A04G	X800 X400	7,55	7,4	7,7	8,0	25,0	33,0	A08T

Bestellbeispiel // Order example: A06.DB29.15.60.20 YR X800 (R = Rechte Ausführung // Right hand version, X800 = Schneidstoff // Grade)