

# Klemmhalter, Innenbearbeitung, Rundschaft, „ME“

Rundschaft aus Hartmetall, besonders geeignet zur Erhöhung der möglichen Auskragung mit unserem neuen ME-Spannprinzip. Das ME-Spannsystem bietet kraftschlüssiges Spannen und dadurch optimale Präzision und Stabilität. Vier Kühlmittelzufuhrarten je nach Bedarf einstellbar.

## Toolholder, Internal Applications, Round Shank „ME“

Carbide round shank, suitable for extending the overall tool reach equipped with our brand new ME-clamping system. The ME-system provides force-fitted clamping along with higher precision and stability. Four different types of through coolant supply can be realized as required.

Anzugsmoment (Schraube) // Tightening torque (screw)

**15,0 Nm - 25,0 Nm**

Bitte Hinweise im Anhang beachten // Please read add. notes

**MASTER (Seite/Page 137), T02 (Seite/Page 138)**

Scan QR-Code Oder besuchen Sie // Or Visit [www.simtek.info/cp/1194](http://www.simtek.info/cp/1194)

Legende Legend **139**

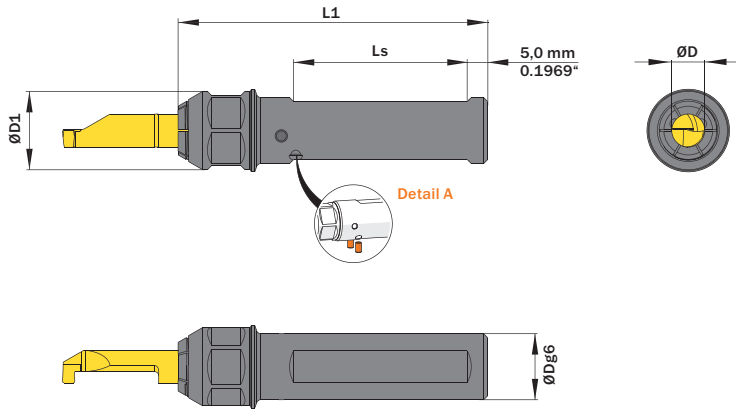

Entdecken Sie unsere simturn AX Halter „ME“. Discover our simturn AX toolholder „ME“.

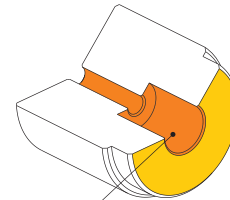

- Hauptsächlich geeignet für diese Flächen  
Mainly designed for these surfaces
- Je nach Schneidplatte ebenfalls möglich  
Also possible depending on insert type

Abbildung zeigt / Drawing shows: A08.0016.ME ST T

ØD	ØDg6	Artikelnummer Part number	Webcode <a href="http://www.simtek.com/webcode">www.simtek.com/webcode</a>	ØD1	L1	Ls	Standard Mutter Standard screw nut	Connectcode <a href="http://www.simtek.com/code">www.simtek.com/code</a>
mm	mm			mm	mm	mm		

Fortgesetzte Tabelle Continued Table **Verwandte Werkzeuge finden Sie auch auf der vorhergehenden Seite!**  
Related Items can be found on the previous page as well!

8,0	15,875	<b>A08.0.625.ME ST T</b>	A012	19,0	75,0	42,0	A00.K.19.15.138	A08 A08T	Inch
8,0	16,0	<b>A08.0016.ME ST T</b>	AY67	19,0	75,0	42,0	A00.K.19.15.138	A08 A08T	
8,0	19,05	<b>A08.0.750.ME ST T</b>	A013	19,0	110,0	75,0	A00.K.19.15.138	A08 A08T	Inch
8,0	20,0	<b>A08.0020.ME ST T</b>	AY7U	19,0	90,0	55,0	A00.K.19.15.138	A08 A08T	
8,0	25,0	<b>A08.0025.ME ST T</b>	AY7V	19,0	110,0	75,0	A00.K.19.15.138	A08 A08T	
8,0	25,4	<b>A08.1.000.ME ST T</b>	A014	19,0	110,0	75,0	A00.K.19.15.138	A08 A08T	Inch

**Verwandte Werkzeuge finden Sie auch auf der folgenden Seite!**  
Related Items can be found on the following page as well!

Fortgesetzte Tabelle Continued Table

Bestellbeispiel // Order example: **A08.0016.ME ST T**

**Detail A | 1 Halter - 4 Kühlmittelzufuhrarten // 1 Toolholder - 4 types of coolant supply**

